This is an electronic reprint of the original article.
This reprint may differ from the original in pagination and typographic detail.

Sepehr, Amir; Pouresmaeil, Edris; Saeedian, Meysam; Routimo, Mikko; Godina, Radu; Yousefi-Talouki, Arzhang

Control of Grid-Tied Converters for Integration of Renewable Energy Sources into the Weak Grids

Published in:

Proceedings of the International Conference on Smart Energy Systems and Technologies, SEST 2019

DOI:

[10.1109/SEST.2019.8849068](https://doi.org/10.1109/SEST.2019.8849068)

Published: 01/01/2019

Document Version

Peer-reviewed accepted author manuscript, also known as Final accepted manuscript or Post-print

Please cite the original version:

Sepehr, A., Pouresmaeil, E., Saeedian, M., Routimo, M., Godina, R., & Yousefi-Talouki, A. (2019). Control of Grid-Tied Converters for Integration of Renewable Energy Sources into the Weak Grids. In *Proceedings of the International Conference on Smart Energy Systems and Technologies, SEST 2019* IEEE.
<https://doi.org/10.1109/SEST.2019.8849068>

This material is protected by copyright and other intellectual property rights, and duplication or sale of all or part of any of the repository collections is not permitted, except that material may be duplicated by you for your research use or educational purposes in electronic or print form. You must obtain permission for any other use. Electronic or print copies may not be offered, whether for sale or otherwise to anyone who is not an authorised user.

© 2019 IEEE. This is the author's version of an article that has been published by IEEE. Personal use of this material is permitted. Permission from IEEE must be obtained for all other uses, in any current or future media, including reprinting/republishing this material for advertising or promotional purposes, creating new collective works, for resale or redistribution to servers or lists, or reuse of any copyrighted component of this work in other works.

Control of Grid-Tied Converters for Integration of Renewable Energy Sources into the Weak Grids

Amir Sepehr, Edris Poursmaeil, Meysam Saeedian, Mikko Routimo
Department of Electrical Engineering and Automation, Aalto University, Finland

Radu Godina
*UNIDEMI, FCT
Universidade NOVA de Lisboa
2829-516, Caparica, Portugal*

Arzhang Yousefi-Talouki
*ABB Oy, Valimopolku 4
00380 Helsinki, Finland*

Abstract—This paper proposes a developed control technique for integration of renewable energy sources into the weak grids. The developed controller alleviates the negative impact of weak grid operating condition on the stability of interface converters by mean of impedance reshaping technique. Furthermore, the proposed controller provides virtual inertia to support the power grid stability. Satisfactory and stable operation of the interface converter as well as providing virtual inertia under weak grid condition with high penetration level of RESs, are the main contributions of this paper. Comparative simulation results are presented to demonstrate and verify the effectiveness of the proposed control technique.

Keywords—frequency stability, power electronic converters, renewable energy sources (RESs), virtual inertia emulation, weak grid.

I. INTRODUCTION

Power electronics is the key to renewable energy integration into the power grid, and power converters as renewable power generation interfaces are co-operating directly with conventional synchronous generators (SGs) in the power system [1]. Currently, power-system inertia is solely caused by the rotating masses of SGs. The rotational inertia, which provides an immediate response to grid frequency disturbances, will be lost in a power electronics-based power system, because power electronic converters do not inherently provide inertia. As a result, the lack of sufficient inertia may challenge the operation and control of modern power systems [1]-[3].

Furthermore, having a high penetration level of distributed generation (DG) greatly affects how the grid is being supported during disturbances and fault situations. Accordingly, power electronic-based converters as the main interface for integrating large-scale renewable energy sources (RES), should control the delivered power to the power grid, and also contribute to the grid stability by supporting grid services (voltage and/or frequency) under generic operating conditions and even during grid faults. In this way, various advanced control methods based on an SG model have been proposed to emulate the SG dynamic response as well as steady-state characteristics by applying a swing equation to provide virtual inertia [3]-[5].

DGs augmented with SG model emulation can use their available dc-link energy by proper energy management to play the role of the rotating mass of SGs, and in turn, provide virtual inertia to the power system. In recent years, various approaches have been developed for control of power electronics interfaced DGs. Significant portions of these approaches require complete calculation of the SG model,

making implementation more complicated and less practical. In a simpler method, proposed in [2], only the essential pieces of the SG model (i.e., the swing equation) is considered, and the rotor frequency is calculated by solving the swing equation. Oscillation damping capability and adjustable moment of inertia also have been discussed in [3]-[6], to improve dynamic response and avoid overcurrent in interface converters.

On the other hand, transition to a sustainable society necessitates energy generation in distributed nodes and even weak grids. Weak grid operating conditions pose substantial challenges to voltage source interface converters including vulnerable synchronization and a critically stable control system. In terms of power system stability and converter control system design, weak grid can be interpreted as a power system where the Short Circuit Ratio (SCR) at the point of common coupling (PCC) is low and significant frequency fluctuations is possibly expected as a consequence of insufficient total system inertia [7]. In brief, a weak grid comes along with voltage fluctuations at the PCC followed by unbalanced and/or distorted voltage waveforms. Furthermore, interface converters may become unstable owing to coupling among multiple parallel power converters, resonances caused by high-order passive filters, and the impact of the phase-locked-loop (PLL) on the current controllers [5], [8]. Notably, the converter instability severely degrades the quality of RES power delivered to the power grid. Moreover, supportive grid services and responsively generating power are tied to properly synchronized voltage reference coordinates. A wide variety of synchronization techniques have been put forward over recent years that can be categorized as open-loop and closed-loop synchronization techniques, mainly include phase-locked loop (PLL), frequency-locked loop (FLL), and integrated synchronization bases. To address grid synchronization instability resulting from PLL dynamics, several methods have been reported in [8]-[11], including reducing the bandwidth of PLL to enhance the stability of grid-connected converters in [9]. Besides, impedance-phased compensation for PLL and reshaping impedance of converters have been tried and tested to present applicable ways to enhance stability under weak grid conditions [10].

In this paper a control technique is proposed to guarantee proper interaction between the interface converters and the power grid. The main contribution of this paper lies in an impedance reshaping and virtual inertia emulation technique using double second-order generalized integrator FLL (DSOGI-FLL) in the $\alpha\beta$ -frame. The proposed technique makes it practicable to achieve supportive services and grid-friendly interaction of the interface converters under weak grid condition.

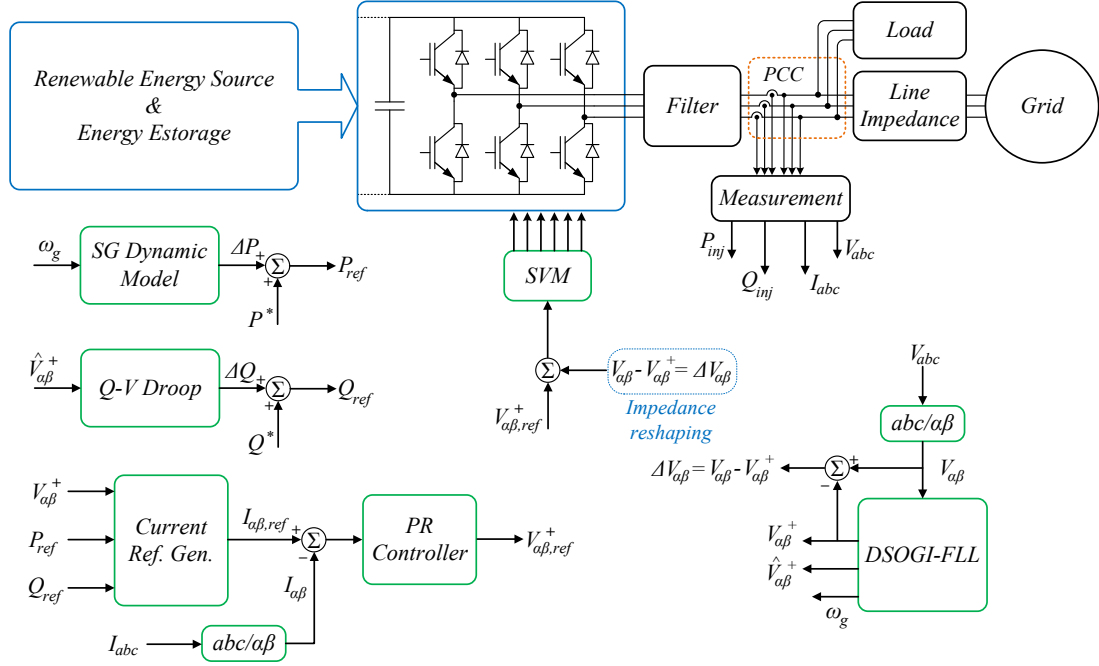

Fig. 1. Layout of the proposed control system for an interface converter.

This paper is organized as follows. Section II describes the proposed interface converter control system. In addition, put forwards the use of DSOGI pre-filtering for impedance reshaping based on voltage feedforward technique. Section III provides case studies and simulation results that reveal the merits of the proposed technique including being actively connected to the weak grid under unbalanced grid impedance condition and providing virtual inertia as a supportive service of the interface converters during disturbances. Section VI summarizes the conclusion of this work.

II. OVERVIEW OF THE PROPOSED INTERFACE CONVERTER CONTROL SYSTEM

Figure 1 shows the layout of a three-phase interface converter connected to a power grid. The proposed interface converter control system includes several interconnected sub-systems working simultaneously to process voltages and currents in order to generate targeted references and provide supportive services. Under weak grid condition, unequal line impedances, unbalanced voltages, and harmonics are presumable, thus computing and extracting positive-sequence component of the PCC voltage is necessary. Accordingly, using a proper synchronization system can enhance converter performance positively. Phase-locked loop (PLL) is a commonly used grid synchronization technique for grid-connected converters whereas under weak grid condition, the coupling between PLL and grid impedance can result in converter instability and injecting harmonics to the grid. One of the main contributions of this paper is to suppress the influences of low-order harmonics of the PCC voltage caused by synchronization technique under weak grid condition, and modify the output impedance of the interface converter. DSOGI-FLL is a developed stationary reference frame synchronization system capable of computing fundamental-frequency positive- and negative-sequence components of the PCC voltage (as shown in Fig. 1) [8], [11]. Besides, the DSOGI-FLL includes an FLL unit that estimates the grid frequency which is an integral part for

providing virtual inertia by emulating SG dynamics. Working in the $\alpha\beta$ domain, just two SOGIs are necessary to compute the symmetrical components in a three-phase application, one for α , and another for β . SG dynamic model, Q-V droop control, current reference generator and controller, and feedforward technique are main parts of the proposed control system discussed in the following sections.

A. SG dynamic model

The SG dynamic model relating the frequency and active power as a function of inertia and damping effect, given as:

$$T_m - T_{el} = J \frac{d\omega}{dt} + B(\omega - \omega_0) \quad (1)$$

where T_m and T_{el} are mechanical torque and electrical torque, respectively, and ω is the SG rotor mechanical angular frequency. In addition, J and B are inertia and damping coefficient in the SG dynamic model, respectively. For further simplification, when implementing SG dynamics in the interface converter, it can be assumed that ω is equal to the angular frequency of the grid voltage (ω_g) computed by the DSOGI-FLL and ω_0 is the rated angular frequency of the power system. Hence, by considering desired value for the planned power P^* , and required power for emulating SG dynamics P_{ref} , active power reference can be calculated from:

$$T_m = \frac{P^*}{\omega_g} \quad \text{and} \quad T_{el} = \frac{P_{ref}}{\omega_g} \quad (2)$$

$$\Delta P = P_{ref} - P^* = -\omega_g \left(J \frac{d\omega_g}{dt} + B(\omega_g - \omega_0) \right)$$

$$P_{ref} = P^* - \omega_g \left(J \frac{d\omega_g}{dt} + B(\omega_g - \omega_0) \right) \quad (3)$$

Since derivative is a non-causal operator, it can be replaced by the following transfer function in the Laplace domain as:

$$s \rightarrow \frac{s}{s + \omega_d}$$

where ω_d adds a delay to the derivative operation and makes it executable to apply inertial response based on grid angular frequency fluctuation. Then, ΔP and P_{ref} can be found as:

$$\begin{aligned} \Delta P_{(s)} &= -\omega_g \left(J_c \frac{s\omega_g}{s + \omega_d} + B_c(\omega_g - \omega_0) \right) \\ P_{ref(s)} &= P^* + \Delta P_{(s)} \end{aligned} \quad (4)$$

Equation (4) is used in the SG dynamic model block in Fig. 1. By applying SG dynamic model and providing virtual inertia J_c and virtual damping B_c , the interface converter contributes to the grid stability enhancement.

B. Q-V droop control

The droop control for compensating positive-sequence voltage drop is applied in the block ‘‘Q-V Droop’’ shown in Fig. 1. This block computes ΔQ in order to regulate positive-sequence voltage amplitude at the PCC and present voltage supportive function under voltage drop condition by adding ΔQ to the planned reactive power Q^* . The reactive power reference Q_{ref} is calculated as:

$$Q_{ref} = Q^* + k_v (\hat{V}_{\alpha\beta}^{rated} - \hat{V}_{\alpha\beta}^+) \quad (5)$$

where $\hat{V}_{\alpha\beta}^{rated}$ is the rated value of the PCC voltage in $\alpha\beta$ frame, $\hat{V}_{\alpha\beta}^+$ is the amplitude of positive-sequence component of PCC voltage in $\alpha\beta$ frame, and k_v is the reactive power droop coefficient

C. Impedance reshaping

The output impedance of the interface converter is based on the converter output voltage and the filter impedance. Feedforwarding the non-fundamental PCC voltage component ΔV to the voltage reference of the converter (demonstrated in Fig. 1), shapes the output impedance of the converter. Fig. 2 demonstrates the impedance-based model of the proposed method. It is important to recognize that the converter voltage includes two constituents, first one is computed by the PR controller to inject desired current and the second one is the feedforward of non-fundamental PCC voltage component. In addition, the mean total time delay T_d for sampling, computing, and switching is given by:

$$T_d = 1.5T_s$$

where T_s is the sampling period of the control system. Converter current can be written as (6):

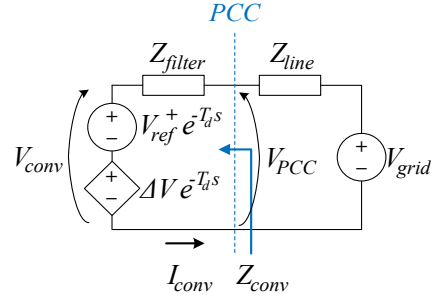

Fig. 2. Equivalent circuit for computing converter output impedance.

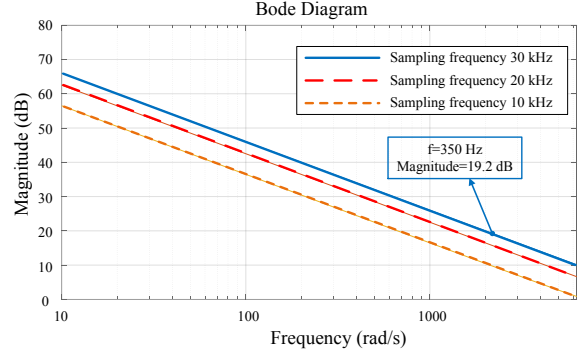

Fig. 3. Bode diagram of the impedance-shaping factor $K_{z(s)}$.

$$\begin{aligned} I_{conv(s)} &= \frac{V_{PCC(s)} - V_{conv(s)}}{Z_{filter(s)}} = \frac{(V_{(s)}^+ + \Delta V) - (V_{ref}^+ + \Delta V)e^{-T_d s}}{Z_{filter(s)}} \\ I_{conv(s)} &= \frac{V_{(s)}^+ - V_{ref}^+ e^{-T_d s}}{Z_{filter(s)}} + \frac{\Delta V(1 - e^{-T_d s})}{Z_{filter(s)}} \end{aligned} \quad (6)$$

Converter current $I_{conv(s)}$ consists of two components, $\Delta I_{(s)}$ is the undesired part of the current that the proposed control technique tries to cancel it by shaping the output impedance of the converter.

$$I_{conv(s)} = I_{conv(s)}^+ + \Delta I_{(s)} \quad (7)$$

Converter impedance corresponding to the non-fundamental PCC voltage component can be calculated as:

$$\begin{aligned} Z'_{(s)} &= \frac{\Delta V}{\Delta I} = \frac{1}{1 - e^{-T_d s}} Z_{filter(s)} \\ K_{z(s)} &= \frac{1}{1 - e^{-T_d s}} \end{aligned}$$

Bode diagram of impedance-shaping factor $K_{z(s)}$ for three typical sampling frequencies is depicted in Fig. 3. Noting that the sampling frequency is normally twice the switching frequency in conventional power electronic converters, as shown in Fig. 3, magnitude of $K_{z(s)}$ for the seventh-harmonic frequency (350 Hz) for sampling frequency of 30 kHz is equal to 19.2 dB, which means large increase in the converter impedance to the wide-ranging harmonics. Moreover, $K_{z(s)}$ brings considerable impedance modification for grid-frequency unbalanced contents, which is generally present due to unequal grid impedances in three phases under weak grid condition.

D. Current reference generator and PR controller

As discussed earlier, the impedance shaping technique blocks non-fundamental current component injection to the grid, therefore, active and reactive power equations for positive-sequence fundamental current reference generation can be expressed as:

$$\begin{aligned} P &= V_{\alpha}^{+} I_{\alpha}^{+} + V_{\beta}^{+} I_{\beta}^{+} \\ Q &= V_{\beta}^{+} I_{\alpha}^{+} - V_{\alpha}^{+} I_{\beta}^{+} \end{aligned} \quad (9)$$

thus the current references can be computed as:

$$\begin{aligned} I_{\alpha,ref} &= \frac{P_{ref} V_{\alpha}^{+} + Q_{ref} V_{\beta}^{+}}{(V_{\alpha}^{+})^2 + (V_{\beta}^{+})^2} \\ I_{\beta,ref} &= \frac{P_{ref} V_{\beta}^{+} - Q_{ref} V_{\alpha}^{+}}{(V_{\alpha}^{+})^2 + (V_{\beta}^{+})^2} \end{aligned} \quad (10)$$

Then, the current references according to (10) are given to proportional resonant (PR) current controller. PR controller is defined by proportional constant K_P and integral time constant K_I as

$$G_{c(s)} = K_P + K_I \frac{s}{s^2 + \omega_g^2}$$

The PR controller has very high gain in a limited frequency band centred at the resonance frequency ω_g . Width of the frequency band depends on the integral time constant K_I , where low values for K_I lead to very narrow bands while high values of K_I broaden the frequency band. Therefore, the controller can be tuned according to the grid requirements. In weak grid applications where the grid frequency is allowed to vary around 1%, an appropriate K_I value can be found by frequency analysis [12], [13]. Moreover, utilizing high-order passive filters for the voltage-source converters has been widely used due to the excellent attenuation performance, smaller size, and lower cost [12], [13]. LCL filter is one of the most popular high-order filters and this type of filter is used in the implemented power converter. In the following, the proposed control technique is simulated and verified in several scenarios.

III. CASE STUDIES

In this section, carried out simulations of the proposed system using MATLAB/Simulink are presented and provided for two case studies. First, the performance of the interface converter when the grid impedance is high and unequal in different phases is discussed. Then, virtual inertia provision under grid frequency drop condition with high penetration level of renewables is demonstrated. Parameters of the simulated system are provided in TABLE I.

A. High and unequal grid impedances

The system short-circuit ratio (SCR) represents the stiffness of the grid to which the interface converter is connected. Generally, a grid with an SCR below 2.5 is considered as weak. Conversely, a grid is defined strong if

TABLE I. PARAMETERS OF THE SIMULATED MODEL

Parameter	Value
Rated Power (S_{base})	600 kVA
Voltage (V_{base})	400 V
Grid Frequency (f_g)	50 Hz
Switching frequency (f_{sw})	4450 Hz
Grid-side filter inductance ($L_{filter,g}$)	0.02 p.u.
Converter-side filter inductance ($L_{filter,c}$)	0.02 p.u.
Filter capacitance (C_f)	0.25 p.u.
Grid impedance (Z_g)	1/SCR p.u.
Phase A grid impedance (Z_{gA})	Z_g
Phase B grid impedance (Z_{gB})	$1.15Z_g$
Phase C grid impedance (Z_{gC})	$0.85Z_g$

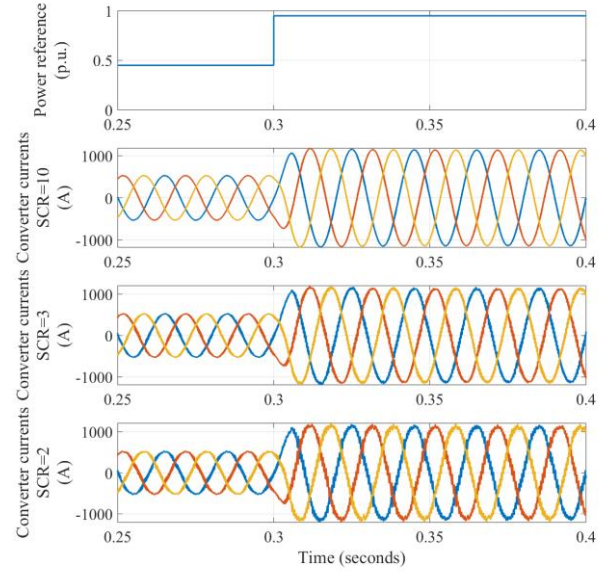

Fig. 4. Power reference step change and converter three-phase currents for different SCR values under unequal phase-impedance condition.

the SCR is greater than 20. The proposed modified control technique was studied by simulation. The simulation results are presented in Fig. 4 for three different values of SCR (10, 3, and 2) and unequal grid impedances in the three phases as summarized in TABLE I.

The system starts with 0.45 p.u. initial active power, then the active power reference changes to 0.95 p.u. at time $t = 0.3$ s, 15% inequality is considered for the grid impedance in three phases. As it is clear in Fig. 4, despite the fact that the converter current quality is degraded by decreasing the SCR value, the converter injects power to the grid steadily and the current quality is still acceptable and the converter stability is ensured for the given values of grid SCR.

B. Virtual inertia provision during grid frequency drop

When a power plant drops off or a large load connects to the grid, there is an immediate shortfall in energy, which causes the grid frequency start dropping. When frequency drops suddenly, the interface converter should release energy to support the grid. This is inertial response, with each unit providing a power increase for a typical large event.

For evaluating the performance of the proposed control technique for providing virtual inertia by the interface converter, a power system including a 2 MW synchronous generator and an interface converter with the rated power of

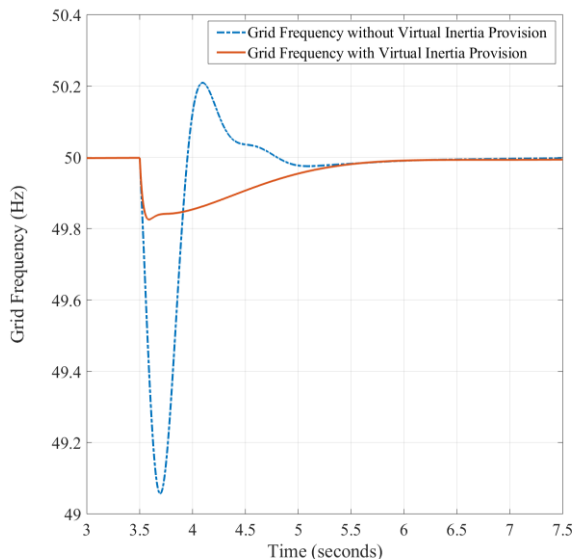

Fig. 5. Grid frequency for two operating modes of lacking virtual inertia and providing virtual inertia.

600 kVA was modelled in MATLAB/Simulink. In this simulation, penetration level of RES is 30%, as shown in Fig. 5 after connecting a large load to the grid, the grid frequency drops to near 49 Hz, which is a considerable frequency drop, and out of the admissible frequency range.

The planned active power for the RES interface converter was set to 100 kW. The simulation has carried out for two modes, in the first one, the interface converter does not provide any virtual inertia and injects just the planned power to the grid (as depicted in Fig. 6), whereas in the second mode, the interface converter provides virtual inertia for supporting the grid frequency. According to TABLE I, the interface converter rated power is 600 kVA, so the converter can provide the peak value of the power shown in Fig. 6 by using storages or other power resources available in the DC side of the interface converter. Fig. 7 shows the three-phase currents of the interface converter for the two aforementioned modes.

According to Fig. 4, 5, 6, and 7, it can be seen that the proposed control technique guarantees that the interface converter can provide supportive services to the grid under weak grid condition, and enhance the stability of the system.

IV. CONCLUSION

This paper has shown that to provide supportive services to a weak grid with high penetration level of RES, it is feasible to take advantage of simplified SG models and modified synchronization techniques. In fact, the main contribution of this paper lies in an impedance reshaping and virtual inertia emulation technique using voltage feedforward method and simplified swing equation, respectively. In the proposed control technique, the developed controller inherently alleviates the negative impact of weak grid operating condition on the stability of interface converters and provides virtual inertia to support the power grid. The proposed technique makes it practicable to achieve supportive services and grid-friendly interaction of the interface converters under weak grid condition.

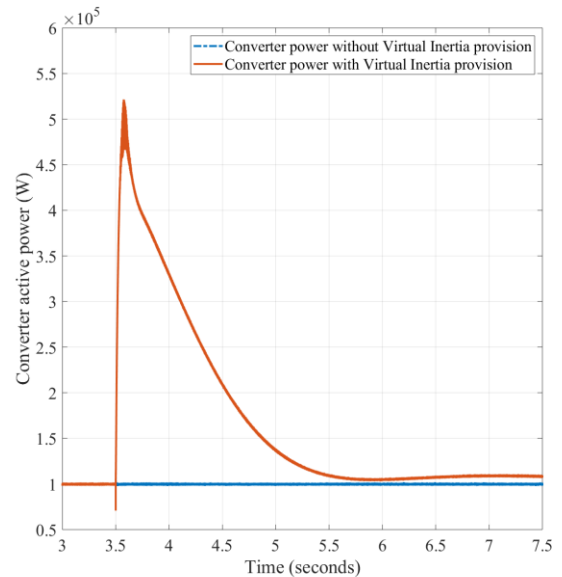

Fig. 6. Converter active power for two operating mode of lacking virtual inertia and providing virtual inertia.

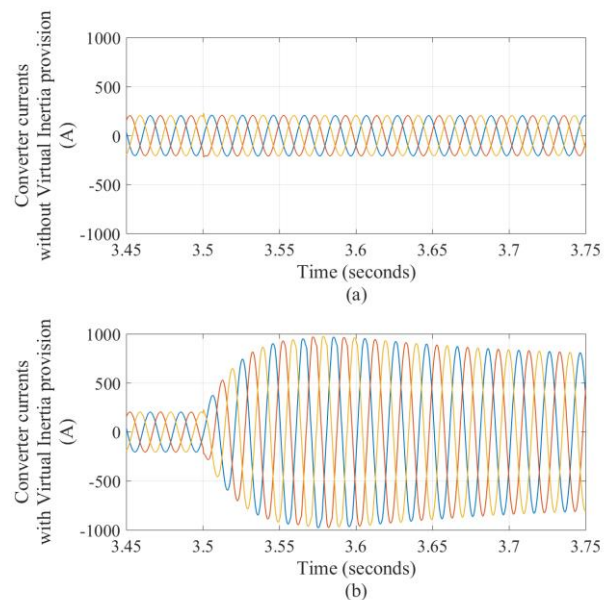

Fig. 7. Converter three phase currents for two operating mode of lacking virtual inertia and providing virtual inertia.

REFERENCES

- [1] M. Mehrasa, E. Pouresmaeil, A. Sepehr, B. Pournazarian, and J. P.S. Catalão, "Control of power electronics-based synchronous generator for the integration of renewable energies into the power grid," *International Journal of Electrical Power & Energy Systems*, vol. 111, pp. 300-314, 2019.
- [2] M. Mehrasa, A. Sepehr, E. Pouresmaeil, J. Kyyrä, M. Marzband, and J. P. S. Catalão, "Angular Frequency Dynamic-Based Control Technique of a Grid-Interfaced Converter Emulated by a Synchronous Generator," in *2018 International Conference on Smart Energy Systems and Technologies (SEST)*, Sevilla, 2018, pp. 1-5.
- [3] M. Mehrasa, E. Pouresmaeil, A. Sepehr, B. Pournazarian, M. Marzband, and J. P.S. Catalão, "Control Technique for the Operation of Grid-Tied Converters with High Penetration of Renewable Energy Resources," *Electric Power Systems Research*, vol. 166, pp 18-28, 2019.
- [4] M. Cespedes, and J. Sun, "Adaptive Control of Grid-Connected Inverters Based on Online Grid Impedance Measurements," *IEEE Transactions on Sustainable Energy*, vol. 5, no. 2, pp. 516-523, April 2014.

- [5] M. F. M. Arani, Y. A. I. Mohamed, and E. F. El-Saadany, "Analysis and Mitigation of the Impacts of Asymmetrical Virtual Inertia," *IEEE Transactions on Power Systems*, vol. 29, no. 6, pp. 2862-2874, Nov. 2014.
- [6] M. Mehrasa, E. Pouresmaeil, B. Pournazarian, A. Sepehr, M. Marzband, and J. P.S. Catalão, "Synchronous Resonant Control Technique to Address Power Grid Instability Problems Due to High Renewables Penetration," *Energies*, vol. 11, no.9, p. 2469, Sept. 2018.
- [7] M. Mehrasa, A. Sepehr, E. Pouresmaeil, M. Marzband, J. P. S. Catalão, and J. Kyyrä, "Stability Analysis of a Synchronous Generator-Based Control Technique used in Large-Scale Grid Integration of Renewable Energy," in *2018 International Conference on Smart Energy Systems and Technologies (SEST)*, Sevilla, 2018, pp. 1-5.
- [8] J. Matas, M. Castilla, J. Miret, L. García de Vicuña, and R. Guzman, "An Adaptive Prefiltering Method to Improve the Speed/Accuracy Tradeoff of Voltage Sequence Detection Methods Under Adverse Grid Conditions," *IEEE Transactions on Industrial Electronics*, vol. 61, no. 5, pp. 2139-2151, May 2014.
- [9] J. A. Suul, S. D'Arco, P. Rodríguez, and M. Molinas, "Impedance-compensated grid synchronisation for extending the stability range of weak grids with voltage source converters," *IET Generation, Transmission & Distribution*, vol. 10, no. 6, pp. 1315-1326, 21 4 2016.
- [10] X. Chen, Y. Zhang, S. Wang, J. Chen, and C. Gong, "Impedance-Phased Dynamic Control Method for Grid-Connected Inverters in a Weak Grid," *IEEE Transactions on Power Electronics*, vol. 32, no. 1, pp. 274-283, Jan. 2017.
- [11] H. Yi, X. Wang, F. Blaabjerg and F. Zhuo, "Impedance Analysis of SOGI-FLL-Based Grid Synchronization," *IEEE Transactions on Power Electronics*, vol. 32, no. 10, pp. 7409-7413, Oct. 2017.
- [12] M. Sanatkar-Chayjani and M. Monfared, "High-Order Filter Design for High-Power Voltage-Source Converters," *IEEE Transactions on Industrial Electronics*, vol. 65, no. 1, pp. 49-58, Jan. 2018.
- [13] M. Sanatkar-Chayjani and M. Monfared, "Stability Analysis and Robust Design of LCL With Multituned Traps Filter for Grid-Connected Converters," *IEEE Transactions on Industrial Electronics*, vol. 63, no. 11, pp. 6823-6834, Nov. 2016.