This is an electronic reprint of the original article.
This reprint may differ from the original in pagination and typographic detail.

Siddiqui, Tauseef; Khanal, Prabhat ; Vähä-Savo, Lauri; Lindvall, Niko; Holopainen, Jari; Viikari, Ville

Bluetooth antenna for metal-cased smart jewellery

Published in:
Electronics Letters

DOI:
[10.1049/el.2019.2887](https://doi.org/10.1049/el.2019.2887)

Published: 06/02/2020

Document Version
Publisher's PDF, also known as Version of record

Please cite the original version:
Siddiqui, T., Khanal, P., Vähä-Savo, L., Lindvall, N., Holopainen, J., & Viikari, V. (2020). Bluetooth antenna for metal-cased smart jewellery. *Electronics Letters*, 56(3), 115-117. <https://doi.org/10.1049/el.2019.2887>

This material is protected by copyright and other intellectual property rights, and duplication or sale of all or part of any of the repository collections is not permitted, except that material may be duplicated by you for your research use or educational purposes in electronic or print form. You must obtain permission for any other use. Electronic or print copies may not be offered, whether for sale or otherwise to anyone who is not an authorised user.

Bluetooth antenna for metal-cased smart jewellery

T.A. Siddiqui^{*}, P. Khanal, L. Vähä-Savo, N. Lindvall, J. Holopainen and V. Viikari

This Letter presents a Bluetooth antenna for metal-cased smart jewellery. The designed antenna is competent enough to operate in free space; moreover, antenna performance is investigated with cubical shape model which has the electrical properties similar to human body tissue. The measured prototype achieves 68% total efficiency in the free space and 27% total efficiency when measured with a cubical model in the Bluetooth frequency range of 2.4–2.48 GHz.

Introduction: The number of smart devices has significantly grown of the past years. These devices, which include smart pendants, smart jewellery, smart watches, smart wristbands, smart clothes and so on are usually referred to as wearables [1]. They often act as an extension to the user interface of smartphone, which is often kept in the pocket or bag. Unconventional objects such as wearable glasses and handbag have also joined into the category of smart devices [2, 3]. Here in [4] are some examples of commercial smart jewellery by Kalevala Koru as well. For aesthetic reasons, the wearable devices should have metallic housing on both sides. The metallic covering on both sides of smart jewellery can improve the rigidity and strength of the device but can also block wireless signals (Wi-Fi, Bluetooth, GPS, or other radio signals) therefore it is always a challenge to design an antenna for such smart wearable applications [5]. Another key factor is the outward appearance of the device, designers put a major focus on stylish appearance and aesthetics rather than just technical specifications. The device design should deliver something that is both functional and fashionable. The size of the antennas in such devices should be small. The antenna should perform in all environments, especially near a human body because most of the time the wearable jewellery is in contact with the human tissue or clothes.

This Letter proposes a half loop-based antenna working in 2.4–2.48 GHz Bluetooth frequency range for a smart jewellery with metal covers on both sides. The existing structure is used as an antenna thus requiring no changes to the visual appearance. The main objective of this work is to design an antenna, which can achieve high efficiency in realistic use cases. There should be a reliable connection in all situations. The proposed solution also gives enough space for the required electronics and a large battery.

Simulation model: The proposed antenna is a half loop-based antenna placed outside the smart jewellery. To start with, the design process, two round metallic covers of copper material is used for practical reasons but in real scenario, these would be the actual jewellery parts made of, e.g. silver or gold. The radius of the front round metal cover is 19 mm with the height of 7 mm and thickness of 1 mm. The radius of the back round metal cover is 16 mm with the height of 6 mm and thickness of 1 mm. The total height of the structure then becomes 13 mm. Between these covers is a 1.5 mm thick printed circuit board (PCB) of FR4 substrate with dielectric permittivity of $\epsilon_r = 4.43$ and a loss tangent of $\tan\delta = 0.027$. The design is simulated using the electromagnetic simulation software CST Microwave Studio.

Parametric study: The main parameters, which affect the performance of the antenna, are the length and height of the antenna arc in terms of matching and efficiency. Different length and height of the antenna arc are studied and simulated keeping in mind the overall aesthetic look of the jewellery. The observation is that the larger the height of the antenna (parameter h_{ant} in Fig. 1), the higher the efficiency. However, the height is limited by the design of the jewellery. Similarly, longer antenna element (parameter l_{ant} in Fig. 1) also improves the antenna efficiency, as the proposed antenna is placed outside the jewellery design, the length of the arc should match with the overall design of the jewellery and should be reasonable. Other factors, such as the size of the metal covers, battery size and PCB, also have an effect but the dimensions of these jewellery parts are kept fixed during simulations, mostly it is determined by appearance of the jewellery and its designer, and are therefore left out of this study. Fig. 1 shows the final dimensions of the prototype and also illustrates the main parameters of the antenna

arc ($l_{ant} = 45$ mm, $h_{ant} = 5$ mm, $t_{ant} = 0.5$ mm). Fig. 2 shows the simulation model and manufactured prototype based on the dimensions shown in Fig. 1.

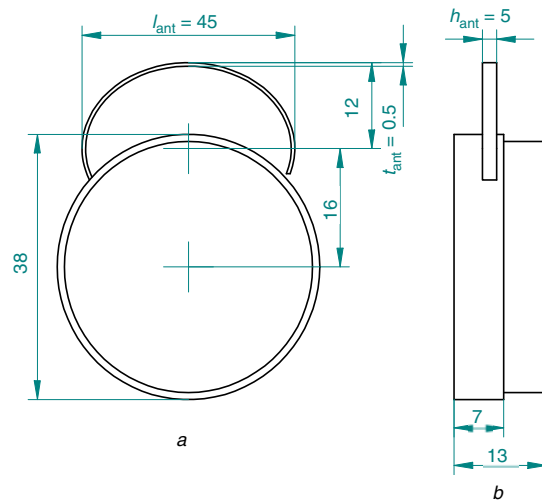

Fig. 1 Jewellery dimensions in mm

a Front view
b Side view

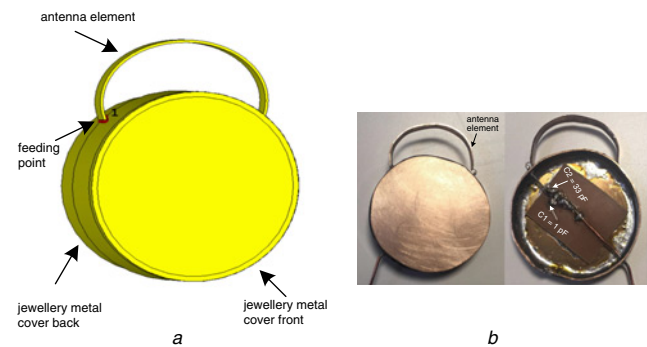

Fig. 2 Jewellery designs

a Simulation model
b Manufactured prototype

Antenna performance: Unlike mobile phones or tablets, smart jewellery is always worn on the human body, so it is more realistic to study the antenna performance near a human body. The cubical model used in the simulations and measurements is a $5 \times 5 \times 5$ cm³ cube of material with electrical properties similar to a human body. According to [6, 7], at the operating frequency of 2.45 GHz, the hand tissue-equivalent medium has $\epsilon_r = 25.7$ and $\sigma = 1.32$ S/m. Ferrites were used around the measurement cables in order to minimise the cable effect during the measurements of impedance matching and total efficiency. The measurements were taken in MVG Starlab 6 GHz antenna measurement system. During the measurements, the cubical model is in direct contact with the metallic part of the jewellery without any gap.

Impedance matching: To achieve operation at the desired frequencies, a lumped component matching circuit is placed between the antenna and the feeding cable. To maintain a simple design and to limit the components, the number of the matching network is kept as small as possible. The chosen topology for the matching network is first a shunt capacitor connected to the source followed by a series capacitor. The components are $C1 = \text{GQM1884C2A1R0BB01}$ (1 pF) and $C2 = \text{GQM1882C1H330GB01}$ (33 pF) SMD capacitors from Murata. When designing and implementing the matching, greater emphasis was given on having a good matching level at Bluetooth frequency range. Fig. 3 presents the measured reflection coefficients of the prototype in free space and with the cubical model. In free space better than 10 dB matching is achieved from 2.40 to 2.44 GHz but when the proposed antenna is placed on the cubical model, the antenna resonance has shifted to lower frequency due to larger ϵ_r of body tissue.

The resonant frequency goes to lower frequency is very typical behaviour and the power absorption to the human body is generally a more severe problem for the total efficiency than the change of matching [8]. The antenna resonance on cubical model shifts to 2.35 GHz but -7 dB matching achieved at 2.4 GHz.

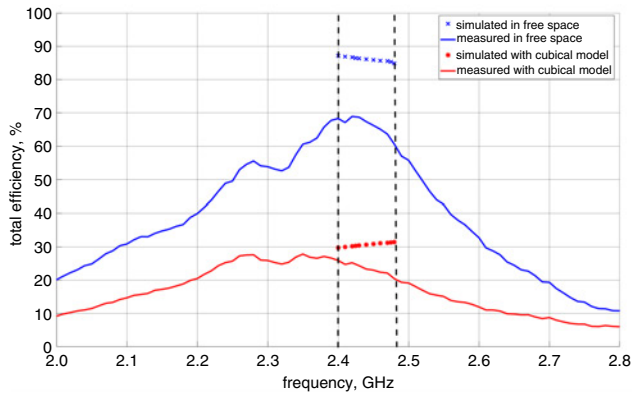

Fig. 3 Measured reflection coefficients in Cartesian coordinates

Radiation pattern: The far-field radiation pattern is measured with MVG Starlab 6 GHz antenna measurement system. Fig. 4 shows the simulated realised gain patterns in free space and with the cubical model and Fig. 5 shows the measured results. In free space the radiation is strongest in the direction perpendicular to the large metal covers of the jewellery but when using cubical model the radiation pattern is directed away from the model and is very strong towards the $+z$ -direction. The coordinate system and the orientation of the antenna are the same in both simulated and measured results.

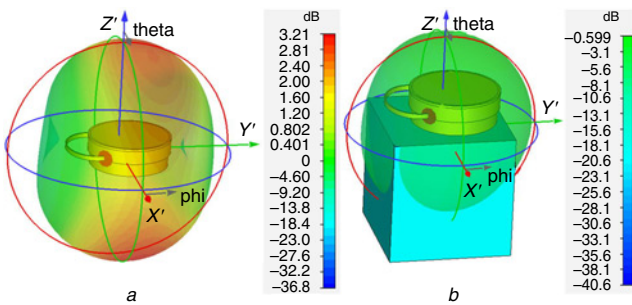

Fig. 4 Simulated realised gain patterns

a In free space
b With cubical model

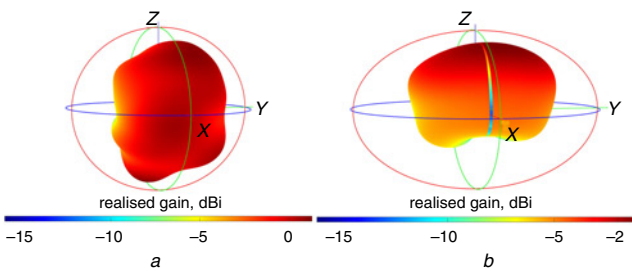

Fig. 5 Measured realised gain patterns

a In free space
b With cubical model

Antenna efficiency: In free space, the total efficiency of the antenna is between 68 and 60%. With the cubical model, the efficiency decreases as compared with the free-space case giving an efficiency of about 27 and 20% in the Bluetooth frequency range. Fig. 6 shows the simulated and measured total efficiency in free space and with the cubical model.

Comparison analysis: It is difficult to compare the proposed design directly with the other published designs [7, 9, 10] because to the best of author's knowledge, such antenna design outside the jewellery

structure has not been broadly presented previously and are unique in smart jewellery applications. For generally comparing the proposed design with wearable Bluetooth antennas, the published designs for the smartwatch are relatively similar. Table 1 sums up the comparison of proposed design with wearable smart device antennas. Also, efficiency better than 15% should be enough for an operation range of 10 m [9]. The performance of the proposed antenna can be considered good after comparative analysis.

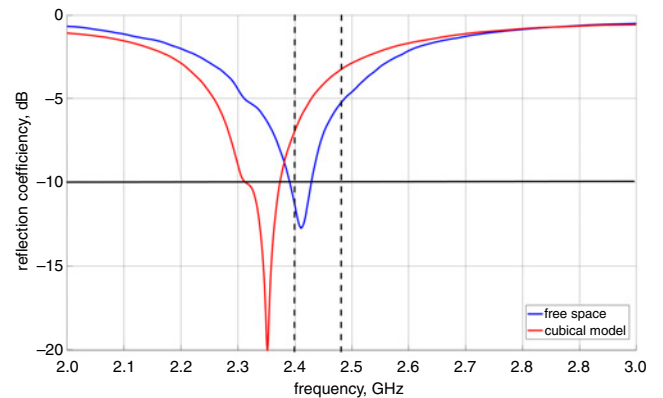

Fig. 6 Simulated and measured total efficiencies

Table 1: Comparison with wearable smart device antennas.

Antenna	Simulated efficiency free space/cubical model	Measured efficiency free space/cubical model
proposed	88%/30%	68%/27%
[9]	69%/26%	67%/N/A
[10]	81%/67%	70%/57%
[7]	75%/65%	N/A/N/A

Conclusion: This Letter has presented an antenna for the Bluetooth frequency range for smart jewellery application. Both simulation and measurement results show that good performance can be achieved when the device is in free space or near a human body. The measured total efficiencies in the 2.4–2.48 GHz frequency range are 68 and 27% in free space and with a cubical model, respectively. Wearable technology has grown rapidly in recent years, and there is a tremendous demand for wearable devices in a different range of applications such as sports, health fitness, and military forces.

This is an open access article published by the IET under the Creative Commons Attribution License (<http://creativecommons.org/licenses/by/3.0/>)

Submitted: 09 September 2019

doi: 10.1049/el.2019.2887

One or more of the Figures in this Letter are available in colour online.

T.A. Siddiqui, L. Vähä-Savo, N. Lindvall, J. Holopainen and V. Viikari (Department of Electronics and Nanoengineering, Aalto University, School of Electrical Engineering, Espoo 02150, Finland)

✉ E-mail: tauseef.siddiqui@aalto.fi

P. Khanal (Chalmers Tekniska Hogskola, Goteborg, 412 96, Sweden)

References

- Seneviratne, S., Hu, Y., Nguyen, T., *et al.*: 'A survey of wearable devices and challenges', *IEEE Commun. Surv. Tutor.*, 2017, **19**, (4), pp. 2573–2620
- Hong, S., Kang, S.H., Kim, Y., *et al.*: 'Transparent and flexible antenna for wearable glasses applications', *IEEE Trans. Antennas Propag.*, 2016, **64**, (7), pp. 2797–2804
- Li, G., Huang, Y., Gao, G., *et al.*: 'A handbag zipper antenna for the applications of body-centric wireless communications and internet of things', *IEEE Trans. Antennas Propag.*, 2017, **65**, (10), pp. 5137–5146
- Kalevala Koru: 'Accessed on 14 June 2019'. Available at <https://www.kalevalajewelry.com/global/jewelry/smart-jewelry>
- TE Connectivity Ltd: 'Antenna Technologies for Wearables', accessed on 14 February 2019. Available at <http://www.te.com/usa-en/industries/consumer-solutions/insights/antenna-technologies-for-wearables.html>
- Hand Phantom: 'Accessed on 14 June 2019'. Available at <https://speag.swiss/products/em-phantoms/phantoms/sho-v3rb-lb/>

- 7 Wu, D., Cheung, S.W., Li, Q.L., *et al.*: 'Slot antenna for allmetal smartwatch applications'. 2016 10th European Conf. on Antennas and Propagation (EuCAP), Davos, Switzerland, April 2016, pp. 1–4
- 8 Holopainen, J., Kivekäs, O., Ilvonen, J., *et al.*: 'Effect of the user's hands on the operation of lower UHF-band mobile terminal antennas: focus on digital television receiver', *IEEE Trans. Electromagn. Compat.*, 2011, **53**, (3), pp. 831–841
- 9 Su, S., and Hsieh, Y.: 'Integrated metal-frame antenna for smartwatch wearable device', *IEEE Trans. Antennas Propag.*, 2015, **63**, (7), pp. 3301–3305
- 10 Wu, D., and Cheung, S.W.: 'A cavity-backed annular slot antenna with high efficiency for smartwatches with metallic housing', *IEEE Trans. Antennas Propag.*, 2017, **65**, (7), pp. 3756–3761