This is an electronic reprint of the original article.
This reprint may differ from the original in pagination and typographic detail.

Le, Thi Minh Khanh; Schreithofer, Nora; Dahl, Olli

Dissolution Test Protocol for Estimating Water Quality Changes in Minerals Processing Plants Operating With Closed Water Circulation

Published in:
Minerals

DOI:
[10.3390/min10080653](https://doi.org/10.3390/min10080653)

Published: 01/08/2020

Document Version
Publisher's PDF, also known as Version of record

Published under the following license:
CC BY

Please cite the original version:
Le, T. M. K., Schreithofer, N., & Dahl, O. (2020). Dissolution Test Protocol for Estimating Water Quality Changes in Minerals Processing Plants Operating With Closed Water Circulation. *Minerals*, 10(8), 1-18. Article 653. <https://doi.org/10.3390/min10080653>

This material is protected by copyright and other intellectual property rights, and duplication or sale of all or part of any of the repository collections is not permitted, except that material may be duplicated by you for your research use or educational purposes in electronic or print form. You must obtain permission for any other use. Electronic or print copies may not be offered, whether for sale or otherwise to anyone who is not an authorised user.

Article

Dissolution Test Protocol for Estimating Water Quality Changes in Minerals Processing Plants Operating with Closed Water Circulation

Thi Minh Khanh Le , Nóra Schreithofer and Olli Dahl

Department of Bioproducts and Biosystems, School of Chemical Engineering, Aalto University, Vuorimiehentie 1, 02150 Espoo, Finland; nora.schreithofer@aalto.fi (N.S.); olli.dahl@aalto.fi (O.D.)

* Correspondence: thi.5.le@aalto.fi

Received: 10 June 2020; Accepted: 21 July 2020; Published: 23 July 2020



Abstract: To save freshwater resources and comply with environmental regulations, minerals processing operations are transitioning to partially or fully closed water circulation. However, the accumulation of electrolytes and the addition of reagents lead to changes in water composition and may compromise flotation performance and plant maintenance. As a consequence, costly modifications are often required to cope with these challenges. Therefore, knowledge about water quality variation owing to closed water circulation and its potential effect on the flotation performance is crucial. The experimental methodology presented in this paper targeted three main objectives: (1) predicting the tendency of the accumulation of elements and compounds into the process water during comminution, flotation, and storage in tailings facilities; (2) establishing a relationship between laboratory results and plant historical water quality data; and (3) predicting the potential effect of recycling water on flotation performance. The results obtained with Boliden Kevitsa ore showed a good correlation between the water matrix of the actual process water on-site and that obtained in the ore dissolution tests done in the laboratory. The final water composition came close to the process water in terms of major elements and some of the minor elements. Additionally, the work presented in this paper demonstrated that a dissolution loop allowed us to predict the potential impact of the recycling water on the ore flotability. This methodology could serve as an aid for predicting water quality matrix variation and designing closed water circulation systems at existing and new plants.

Keywords: water management in mining; prediction of water variation; water recycling in mining; effect of recycled water on flotation; flotation

1. Introduction

Due to water scarcity in many regions in the world and environmental regulations enforced by the governments, mining operations need to lower their freshwater intake used for metallurgical processes and the volume of wastewater discharged in the surrounding environment. For this reason, closed water circulation solutions are progressively adopted to reduce water consumption and environmental footprints of the mining industry. However, the impacts of recycling on water quality are obvious and well documented in the literature [1–6]. Already since the 1980s, publications pointed out that flotation in fresh-water and recycled water with the same ore in the same conditions often produced different results. At the same time, modern flotation concentrators are still designed and optimized based on several metallurgical batch flotation and pilot-scale tests using only fresh tap water in the location where the testing is done. In other words, the effect of water recycling on flotation performance is not included in the plant design and process selection. Consequently, this action contributes to the gap between laboratory results and true plant performance [7].

The literature indicates that the accumulation of dissolved species—both organic and inorganic, suspended solids (SS), residual reagents, and bacteria—can have detrimental impacts on the froth flotation performance, but some positive effects also exist [1,2,4,8–10]. However, as the variation of water quality due to recycling is various and case dependent, its impacts are also case dependent.

Commonly, the first effect of recycling on water quality is the accumulation of total dissolved solids (TDS) due to the dissolution and oxidation of the ore. Additionally, the inorganic ions derived from the flotation reagents also slightly contribute to this increase of TDS [11]. The literature indicates that the accumulation of species can have negative effects on the success of the froth flotation process, but some positive effects also exist [4,6,8,9]. However, in some cases, the effects might only be seen months after recycling started due to the time delay from the tailings storage facilities to the plant [4] and time to reach a concentration high enough for the process to be affected [12]. It is well-known that the presence of salts in water plays an important role in the stabilization of the froth [13]. Wellham et al. (1992) [14] and Kurniawan et al. (2011) [15] proved that high salt concentration (NaCl) had a positive effect on the flotation of nickel sulfide minerals as it induced particle coagulation and reduced electrical double layer between the particles and the air bubbles. However, when the concentrations of species become too high and, at the same time, the conditions change to favor precipitation, it can represent a threat to the process. It was documented by Levay et al. (2001) [16] and Rao and Finch (1989) [6] that the sudden changes in pH and Oxidation Reduction Potential ORP could precipitate colloidal particles as crystallites and gels, which could remain dispersed in solution or attached to mineral particle surfaces and create a hydrophilic surface layer. Additionally, it was recognized that the dissolved species precipitating as metal hydroxide due to the pH adjustment process could coat the minerals and then reduce the recovery of the valuable minerals [17,18].

The recycling of water could increase the amount of suspended solids (SS) in the water, particularly in short water cycle systems [2]. The accumulation of fine gangue and clay minerals could cause the formation of slime coatings in the surface of minerals, which can dramatically reduce the flotation of, e.g., pentlandite due to the modification of surface charge [19].

Another factor leading to undesirable results in the selectivity is the residual reagents (mostly xanthate in sulfides flotation) and their decomposition products, such as dixanthogen, which is well-known to induce non-selective flotation. The accumulation of reagents and their derived decomposition compounds is common but not always observed [2]. The recycling of reagents can be beneficial as reducing the reagent consumption of the plant both in milling [20] and flotation circuit. Forsberg and Hallin (1989) [4] stated that after starting the recycling of water, a reduction of 50% of the previously used amounts of reagents was sometimes necessary. However, the recycled collectors can have a deleterious effect on a flotation plant, where two or more concentrates are produced in a sequential circuit [1,21] as it decreases the selectivity.

Furthermore, the recirculation of water generally increases the accumulation of heat and nutrients that favors the development of bacteria or different organic species, which could act as surface activators, dispersants, or flocculants and interfere with the flotation process [4,6,9,16,22].

It is evident that the recycling of water can impact the water quality and compromise the plant performance. However, water management is usually not included in the plant design and process selection. To date, no laboratory set-up dedicated to predicting the variation of process water quality due to the closed water circuit is found in the literature. Few references are found on the prediction of mining wastewater quality [22–24]. They are mostly based on thermodynamic calculation and focused on waste rock. The main disadvantage of using a thermodynamic calculation to predict water quality is the gap between thermodynamic and kinetic. The thermodynamic calculation might help to predict the final stage of the water, but powerless in the case the kinetic reaction governs the system [24]. In a recycling water system, especially in a short water cycle, the kinetic might govern since the water quality variation can be expeditious. Therefore, there is a need to set-up a test protocol to predict empirically the water variation due to close water recirculation in the mineral processing plant.

This study aimed to provide a test protocol that allows the prediction of (1) the variation of the water quality over time owing to the dissolution of the ore when the plant is operated in a closed recycle water circuit and (2) its application on predicting the impact of recycling water on flotation performance. This information could provide help when designing water circulation systems at both existing plants (brownfield) and new plants (greenfield). The test protocol was set up based on the following assumptions that are discussed in more detail in Section 5: (1) Process water is mine-specific, dynamic, unstable, and complex, so a pure approach using synthetic plant water is not suitable to investigate the effect of water quality on the plant flotation performance. (2) The prediction of the water quality variation could be possible if we mimic the pathway of the ore in the plant. The easiest way to mimic this is by using the laboratory flotation procedure used by the same plant. (3) If the water quality could be predicted, then its effect on the flotation and plant maintenance could also be predicted with some degree of uncertainty. (4) The prediction of water quality is not only important for improving performance purposes but also for plant design purposes. Knowing the existence of a potential component that might affect the process performance or maintenance (e.g., scaling or gypsum) could help the design of the plant in the early phase. (5) Such a test protocol can complement the traditional pure synthetic water approach for studying the effect of recycling water on flotation performance. Indeed, if the test protocol can help to create baseline water similar to the actual process water and, at the same time, conserving its most important characteristics (i.e., mine water and, at the same time, conserving its most important characteristics (i.e., mine-specific, dynamic, unstable, and complex), the effect of specific compounds can be detected by spiking dynamic baseline water with different compounds that are expected to accumulate.

2. Materials and Methods
2. Materials and Methods

2.1. Mine Site, Mineralogy, and Water Circuit
2.1. Mine Site, Mineralogy, and Water Circuit

The Boliden Kevitsa processes low-grade Cu–Ni ore. The ore is enriched in Cu and Ni with chalcopyrite, cubanite, and pentlandite being the main valuable minerals of interest [25]. The sulfide is mostly disseminated, and no strong variation in terms of mineralogy is observed throughout the ore body [26]. The ore from the open pit is crushed in the comminution circuit to obtain the suitable particle size for flotation. The flotation circuit is sequential, with copper being floated first, followed by a nickel to produce two concentrates (Figure 1) [25]. The remaining sulfide minerals in the nickel tailings are removed as high sulfur tails in the last flotation step and stored in the high sulfur ponds (TSFA). While the final tails of the process are stored in the low sulfur pond (TSFB). The water of all tailing ponds and pit is collected in the reservoir to form the process water. Besides that, the copper and nickel concentrate thickeners overflows are recycled, respectively, in the copper and nickel circuits.

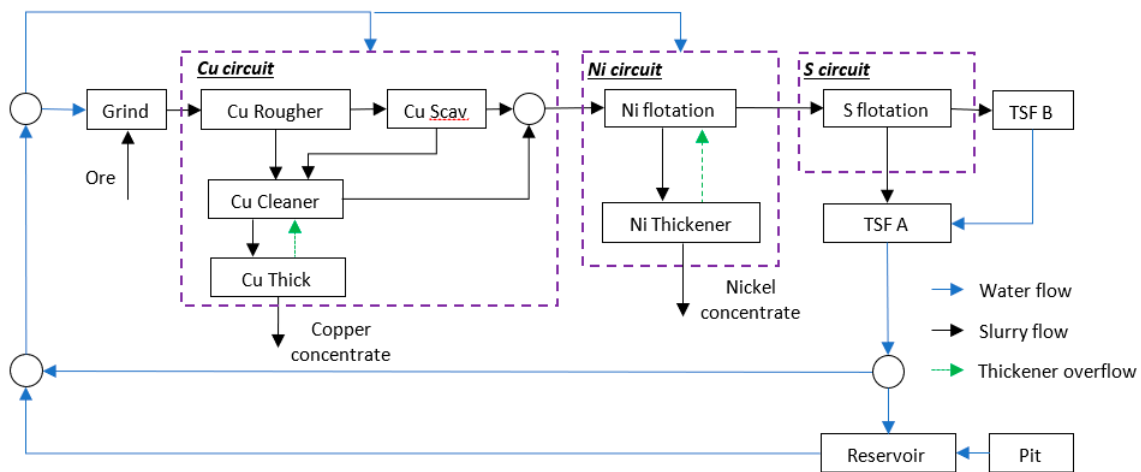

Figure 1. Flotation and water circuits of the Boliden Kevitsa mine.

The process water is recirculated since the beginning of the mine operation in 2012. The plant process water is defined as the water that is fed to the milling circuit and the flotation tanks. The quality of the plant process water has been monitored since July 2013 by taking samples at the process water tank (prior to feeding to the plant). In this paper, the results of the dissolution test were compared to the most recent available values observed for the plant process water during a period of 4 months in summer 2018.

The temperature of the process water in the feeding point ranges from 0.5 to 15 °C. However, shortly after entering the circuit, the temperature of the process water increases significantly due to the energy provided by the milling process and flotation process. In winter, the slurry temperature can reach a constant temperature between 12 and 15 °C along the process, and in summer, the slurry temperature is between 22 and 25 °C. During the peak of the heat that could occasionally happen in the North of Finland, the temperature of the slurry can reach as high as above 30 °C.

2.2. Ore and Water Samples

The study was conducted with Boliden Kevitsa low-grade Cu-Ni ore. The ore sample was provided by Boliden Kevitsa mine and sent to the Aalto University for ore preparation and preliminary testing. The ore contained 0.2% Cu, 0.2% Ni, 9% Fe. Almost 95% of the ore is non-sulfide minerals. The mineralogical and chemical composition of the ore is presented, respectively, in Supplementary Tables S1 and S2.

The ore was crushed to −3 mm, split, vacuum-packed into 1 kg samples, and stored in a freezer to avoid oxidation. The preliminary testing was performed at the Aalto University in order to design the final protocol. Afterward, the ore was sent back to Boliden Kevitsa mine. All experiments reported in this paper were carried out at the mine site since some tests required local raw water and process water. The dissolution tests with distilled water (DW) and local river water (RW) were carried out to investigate if it was possible to produce a water matrix that was close to the current composition of the plant process water. The composition of the RW is shown in Supplementary Table S3.

Due to the mild high temperature of the slurry along the process, all experiments were carried out at 20 °C. Besides, the dissolution test with DW was performed at 5 °C and 35 °C to study the effect of the temperature on the ore dissolution. The full dissolution loop with RW at 20 °C was performed twice to analyze the reproducibility of the tests.

2.3. Dissolution Loop Protocol

One round of the dissolution loop consisted of two major steps: grinding and dissolution (Figure 2). The ore sample was subjected to 27 min of grinding in Boliden Kevitsa stainless laboratory rod mill. The particle size distribution of the sample after grinding is shown in Supplementary Figure S1. The mill was maintained at low temperatures with dry ice and high temperatures with heating bags. After milling, the pulp density was adjusted, and the slurry was transferred to a two-liters flotation cell for the dissolution test. The dissolution procedure followed the Kevitsa laboratory flotation procedure in terms of percentage of solids, duration, rotor rotation speed, and the airflow rate but without the addition of reagents (except pH modifier). Therefore, there was no froth removal during the test. Lime, as a pH modifier, was added under monitoring with pH-meter. The objective was to obtain a similar pH during dissolution and flotation. The temperature was maintained by ice, dry ice (5 °C), and heating elements (35 °C). The slurry temperature was frequently monitored during the dissolution by a thermometer. After dissolution, the slurry was filtered with a vacuum pump. The solids were discarded, while the filtered water was recovered. VWR Qualitative filter paper, 415 with a particle retention capacity of 12–15 µm was used for the filtration. Afterward, 100 mL was either sent to analysis or discarded to maintain the water balance. Starting water was added to the remaining filtered water to compensate for the loss and was used in the next dissolution round.

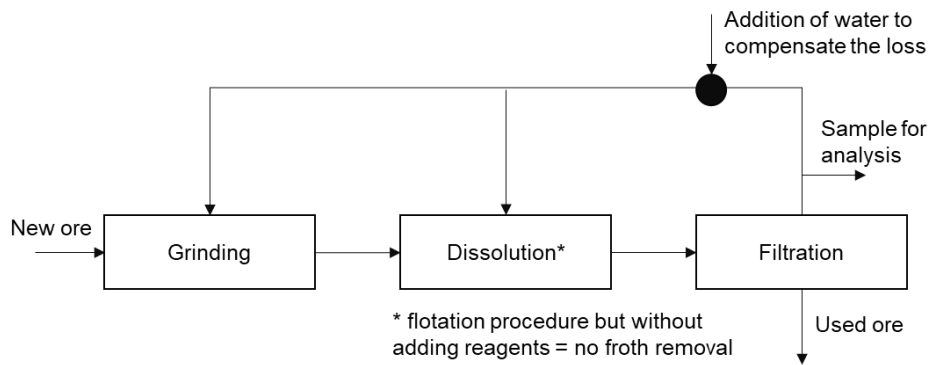

Figure 2. Overview of the dissolution test procedure.

In this case of the Kevitsa ore, one dissolution loop test comprises of 8 rounds. The number of dissolution loops was decided based on the preliminary testing, where 14 dissolution rounds were performed, and only specific conductance (SPC) was monitored. It was shown that SPC started leveling off after the 8th round. The water composition was analyzed from 100 mL water samples at the beginning of each test (0 water) and the end of rounds 1, 3, 6, and 8.

Water samples were prepared according to the recommendations of the analytical laboratory contracted by the project. The water samples were filtered by a vacuum filter (Duran, DWK Life Sciences, Germany) at 1.6 µm (and at 0.45 µm in the laboratory) for anion analysis and with 0.45 µm by syringe filters for elemental analysis. All samples for anion analysis were fast-frozen in the dry ice-acetone cooling bath to prevent degradation of thiosalts before sending them to the laboratory for analysis. The analysis methods, detection limit, and margin of error are shown in Supplementary Table S4.

The evolution of the water matrix during the dissolution test was reported as a function of the solid to liquid (S/L) ratio. It was defined as the accumulated mass of new ore divided by the mass of water recycled. Basically, this ratio defined the amount of time that water has been recycled in the system. The main reason for using the S/L ratio instead of round number was to later facilitate the scale-up from laboratory to industrial scale.

2.4. Analysis Methods

The physicochemical parameters of the waters such as temperature, pH, oxidation reduction potential (ORP), specific conductance (SPC), dissolved oxygen (DO) were measured with the YSI ProDSS multiparameter probe (YSI, Xylem Inc., Yellow Springs, OH, USA). The sensors were checked before each round of tests and calibrated when needed. The elemental compositions of the water were analyzed with inductively-coupled plasma (ICP) (Agilent 8800 ICP-MS, Agilent Technologies, Santa Clara, CA, USA), while the anions (sulfate, chloride, and thiosulfate) concentrations were determined with ion chromatography (ICS-1500, Dionex, Sunnyvale, CA, USA). However, due to a technical mistake from the analysis, the laboratory, sulfate, thiosulfate, and chloride analyses were missing for the samples from the dissolution with DW at 35 °C.

3. Results of the Dissolution Loop

3.1. Changes in the Physicochemical Parameters of the Water as a Result of Ore Dissolution

The monitoring of physicochemical parameters of water during the dissolution test was indispensable as it revealed the major evolution direction of the water matrix and the state of the reproduction of the test. The variation in terms of physicochemical parameters, as shown in Table 1, indicated a good reproducibility as they were generally lower than 15%. The variation for the ORP value was slightly higher due to the presence of several redox couples in the sulfide flotation pulp, which rendered the ORP measurement more difficult and uncertain [4].

Table 1. The reproducibility of the dissolution test in terms of physicochemical parameters.

Round Number	Round Number	Elements/Compounds			
		SPC ($\mu\text{S}/\text{cm}$)	pH	ORP (mV/(Ag/AgCl))	DO (%)
0		34 ± 5	6.02 ± 0.68	234 ± 42	103.2 ± 0.1
1	0	825 ± 62	9.14 ± 0.06	157 ± 15	103.2 ± 0.1
2	1	1218 ± 85	9.08 ± 0.03	123 ± 15	49.2 ± 7.0
3	2	1546 ± 57	9.06 ± 0.04	105 ± 2	55.8 ± 2.9
4	3	1751 ± 52	9.04 ± 0.02	124 ± 11	51.9 ± 3.3
5	4	1865 ± 3	9.12 ± 0.01	115 ± 1	43.6 ± 3.5
6	5	1946 ± 6	9.03 ± 0.08	119 ± 7	47.5 ± 3.1
7	6	1987 ± 12	9.01 ± 0.08	110 ± 17	52.8 ± 7.1
8	7	2018 ± 16	9.18 ± 0.02	110 ± 4	49.0 ± 3.3
	8	2018 ± 16	9.18 ± 0.02	110 ± 4	56.2 ± 0.4

SPC: Specific conductance; ORP: oxidation reduction potential; DO: dissolved oxygen.

The variations of the physicochemical parameters were recorded throughout the experiments and were compared with the historical maximum and minimum values measured at the Boliden Kevitsa process water between February 2017 and February 2018 (Figure 3). The high ORP value in RW starting water was indicative of the presence of strong oxidizing compounds like iron, which was later confirmed by water analysis.

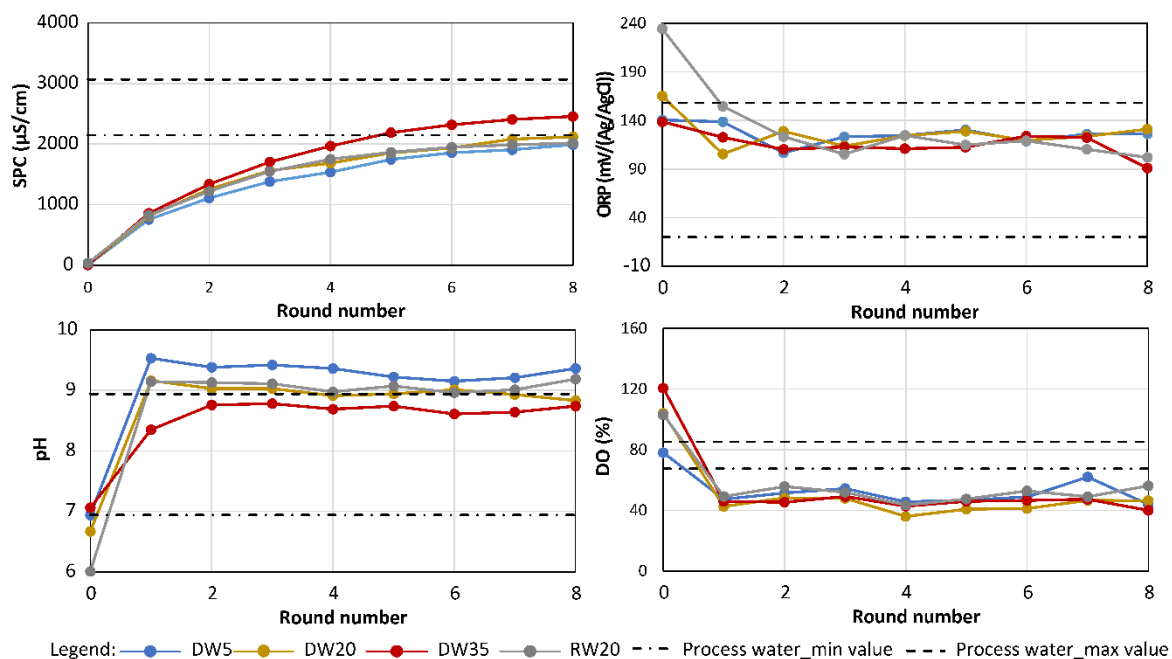

Figure 3. SPC, ORP, pH, and DO measurements for different water types as a function of dissolution round number.

Closer inspection of the results showed a tendency of raising SPC. SPC over the dissolution rounds appeared as a bell curve, it indicated that an accumulation of species dissolved in the water. The rate of dissolution decreased gradually and the conductivity tended to level off at the end of the experiment. This result supported the idea of an equilibrium point between the ore and the water matrix, which prevented a non-stop accumulation of elements/compounds into the recycled water. Additionally, at the end of round 8, the SPC of the recycled water reached the value range observed in the mine.

The variation of DO and ORP correlated as oxygen is theoretically the most important oxidizing agent. Both ORP and DO curves showed a quick drop after the first dissolution round and then stabilized over consecutive rounds. The drop of DO can be explained by the consumption of oxygen by the minerals for oxidizing the mineral surfaces. The low value of DO in the test compared to the

stabilized over consecutive rounds. The drop of DO can be explained by the consumption of oxygen by the minerals for oxidizing the mineral surfaces. The low value of DO in the test compared to the plant value was most likely due to either by the closed grinding system used in the laboratory or the lower aeration rate in the laboratory flotation cell compared to the industrial flotation tanks.

The pH variation during the dissolution depended strongly on the temperature. The dissolution at a high temperature tended to decrease the pH. A possible explanation for this might be that temperature enhanced the oxidation of sulfur-reduced compounds to a higher degree of oxidation, such as sulfite, thiosalts, and sulfate, which resulted in an acidification of the pulp [27]. According to this data, we could infer that changing the operating conditions of the plants should be considered according to temperature variation. As the plant would consume more calcium hydroxide in summer-time when the pulp temperature could reach as high as 30 °C than winter-time when the pulp temperature is around 10–14 °C (in plants operating with AG milling, such as the studied case), the pulp temperatures are lower than in operations using a ball mill.

3.2. Changes in the Chemical Composition of the Water as a Result Of Ore Dissolution

3.2.1. Dissolution of Major Elements

The coefficient of variations for major elements/compounds, such as potassium, calcium, magnesium, sodium, total sulfur, sulfate, and chloride, were generally lower than 10% (Table 2), indicating good reproducibility. For minor elements, like metals, silica, and phosphorus, the reproducibility was not as good. The average coefficient of variation was 23% for phosphorus, 96% for cobalt, 27% for copper, and 67% for nickel. The iron levels of all samples, except for the zero samples, were below the detection limit (0.05 mg/L) and, therefore, were not reported.

Table 2. The reproducibility, expressed by the coefficient of variation (%), of the dissolution with RW in terms of water composition.

Round Number	Elements/Compounds												
	K ⁺	Ca ²⁺	Mg ²⁺	Na ⁺	Total S	SO ₄ ²⁻	Cl ⁻	S ₂ O ₃ ²⁻	Si	P	Co	Cu	Ni
0	5.9	2.5	0	6.1	5.1	2.2	3.1	2.5	12.9	9.4	141.4	7.6	11.8
1	6.1	8.1	9.4	5.0	9.6	0	2.1	3.1	19.9	41.1	141.4	61.4	75.6
3	0	2.3	8.8	0	5.2	2.4	2.7	2.5	18.7	28.7	53.6	16.3	63.9
6	3.8	6.4	1.1	0	7.4	N.A	N.A	N.A	0.9	10.2	45.4	17.7	45.5
8	8.3	3.0	3.0	3.6	10.3	N.A	N.A	N.A	5.7	24.0	98.3	33.4	141.0

K⁺: potassium, Ca²⁺: calcium, Mg²⁺: magnesium, Na⁺: sodium, total S: total sulfur, SO₄²⁻: sulfate, Cl⁻: chloride, S₂O₃²⁻: thiosulphate, Si: silicon, P: phosphorus, Co: cobalt, Cu: copper, Ni: nickel.

The variation of concentration, in terms of major elements/compounds, as a function of the solid to liquid ratio (S/L), as shown in Figure 4, indicated a tendency of increasing over rounds. However, while potassium, calcium, magnesium, sodium, total sulfur behaved similarly to the SPC (i.e., leveled off at the end of the test), sulfate, thiosulfate, and chloride were still slowly increasing. This finding was consistent with the selective accumulation of compounds observed in the historical data of the plant. The leveling off of some compounds supported the hypothesis that those compounds were removed through adsorption onto mineral surfaces and deposited in the tailings storage facilities, as observed by other authors as well [2].

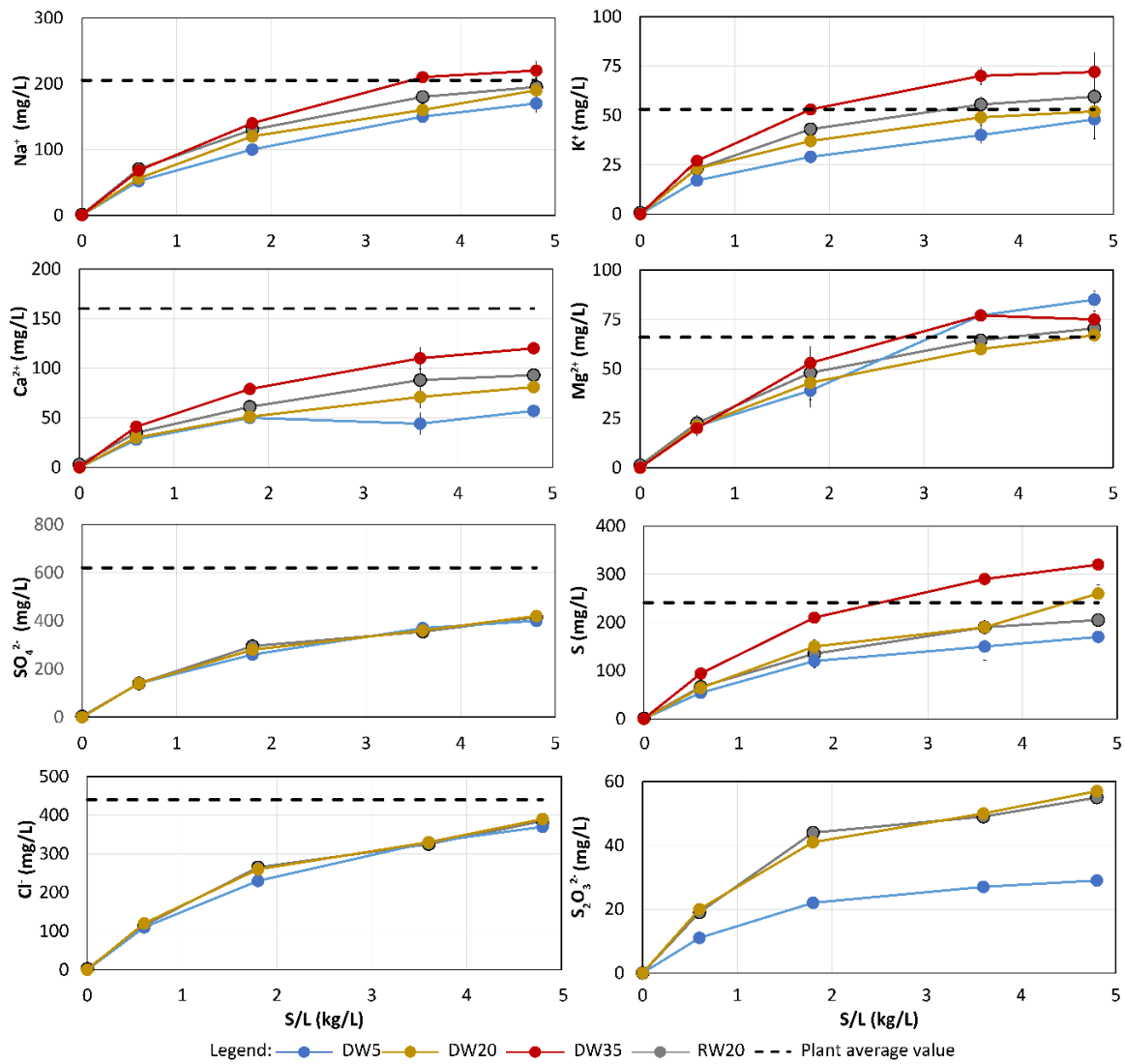

Figure 4. The concentration of major elements in the recycled water as a function of the solid to liquid (S/L) ratio.

3.2.2. Dissolution of Various Elements
 During the dissolution, 12 mL of calcium hydroxide at 10 g/L was added for each round to maintain the pH of the slurry close to the pH of the plant concentrator circuit. Therefore, a linear rise of 45 mg/L of calcium was expected for each round on top of the own dissolution from the ore. However, the variation of calcium concentration of the current study did not meet that expectation. The leveling off of calcium at 100 mg/L implied a disappearance of calcium from the recycled water. Schumann et al. (2009) documented very similar phenomena in the case of mine processing copper–gold ore using flotation with short recycling water. During the first six years over the ten years of operation, the total dissolved solids (TDS) raised from 400 to 800 mg/L, and then it stabilized around 800 mg/L over the next four years. The level of calcium and sulfate also leveled off without any clear reason, and calcium also reached a plateau faster than sulfate. The same study suggested, with the solution speciation modeling, that the precipitation of calcite probably controlled the levels of calcium in the process water. Calcium can also be removed by adsorption in the sulfide minerals and then be removed by the flotation process [5]. A study performed by Ikumapayi (2015) supported this assumption by showing a balance of disappearance of calcium in the process water around 100 mg/L during the flotation of sulfide ore [28]. Since calcium is playing a certain role in the creation of a bond between the reagents and the surface minerals, it might adsorb on the minerals' surface, even without the presence of reagents [29]. Moreover, calcium is also known to be adsorbed onto silicates minerals [30–32].

Since 90% of the ore used in this study was silicate, it could be the main reason why calcium was removed from the system. Additionally, the low solubility of calcium hydroxide could also contribute to such observation. The minimum solubility of calcium hydroxide at 298.15 K is 2.749 g/L at the pH value located at 12–14 [33]. Therefore, calcium hydroxide was mostly insoluble in the solution of calcium hydroxide at 10 g/L that was prepared for modifying pH. Since most of the calcium hydroxide introduced in the system was in the form of a precipitate, it could happen that the calcium hydroxide did not have enough time to get dissolved in the flotation tank during the dissolution.

3.2.2. Dissolution of Minor Elements

Figure 5 provides the changes in terms of minor elements as a function of the S/L ratio. What stands out in the figure is the change in the concentration of minor elements, particularly for the fact that these values were difficult to explain at first, but the magnitude of the fact that the dissolution was rapid and the first tendency of the major elements. Their dissolution rates did not rapidly with the same tendency. The final concentrations of the dissolved elements RW and DW were similar, except for with RW. The amount of silicate of each 8 mg/L silicate is dissolved higher in the DW with RW. The amount of silicate reached 8 mg/L, while in the dissolved water in DW was only 5 mg/L. The latest concentration value of silicate in the dissolved water is RW 8 mg/L, a value similar to the one obtained with the dissolution with RW.

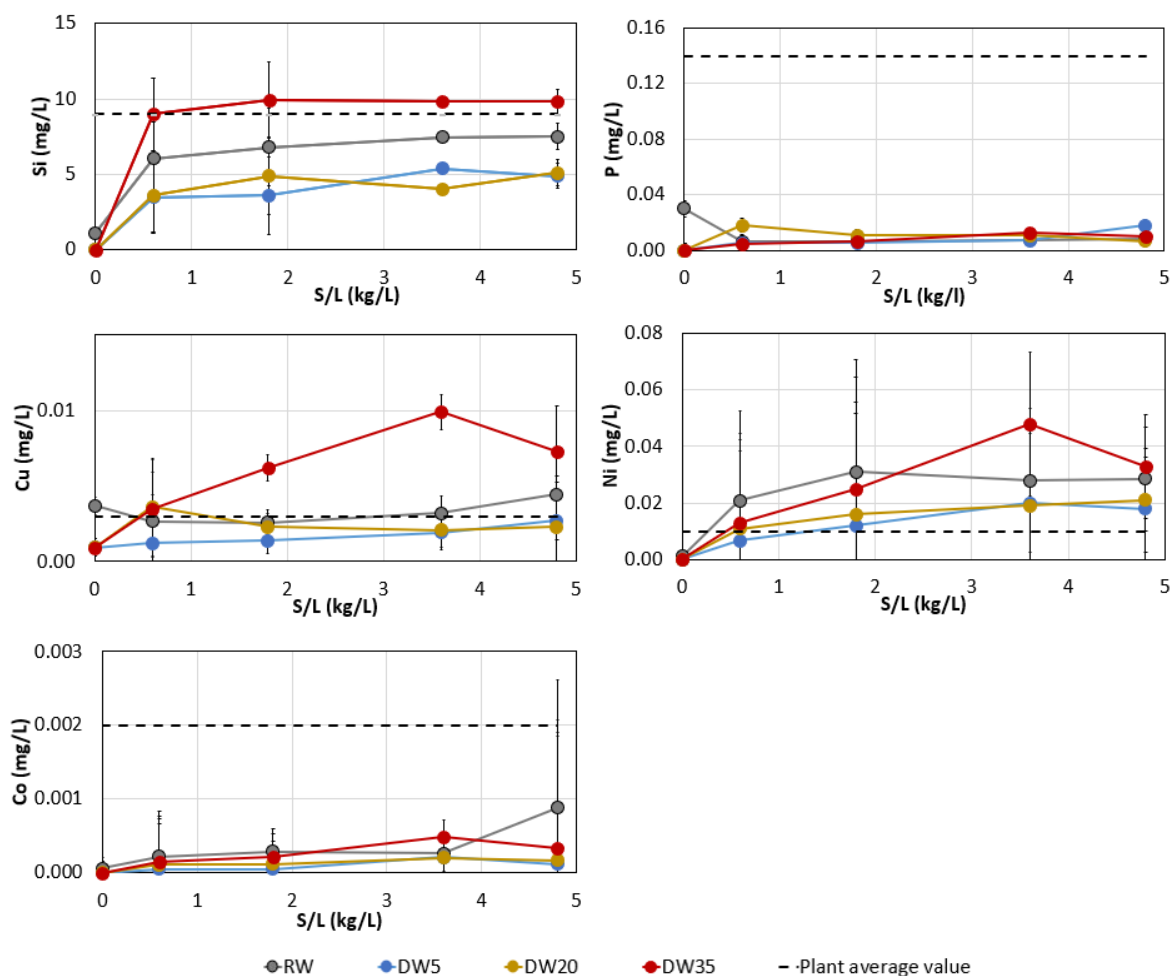

Figure 5. The concentration of minor elements in the recycled waters as a function of the S/L ratio.

The low concentration of metals in the systems may be related to the slightly higher pH in the dissolution water compared to the pH observed in the process water. The pH from the dissolution loop, even though, was found in the range observed at the process water data but was slightly higher. The t-test results for comparing means of the pH from dissolution and the pH observations in the process water are provided in the Supplementary Table S5. The low value of p (<0.01) for the one side test indicates that the null hypothesis can be rejected, and the quantities differ in a particular direction. Indeed, the process water pH varies mostly around 7.5–8.5, while the pH of the water from the dissolution was around 8.6. This difference in pH could be related to the fact that the dissolution

loop, even though, was found in the range observed at the process water data but was slightly higher. The *t*-test results for comparing means of the pH from dissolution and the pH observed in the process water are provided in the Supplementary Table S5. The low value of *p* (<0.01) for the one side test indicates that the null hypothesis can be rejected, and the quantities differ in a particular direction. Indeed, the process water pH varies mostly around 7.5–8.5, while the pH of the water from the dissolution loop varies mostly around 8–9. That is a direct consequence that our test did not simulate the tailings pond of the plant, which is the location when the oxidation reaction of sulfide occurs continuously and, as a consequence, reduces the pH [27,34]. At this slightly basic range of pH, a slight increase in pH could strongly decrease the solubility of metal hydroxides [35].

3.3. Comparison between Laboratory and Plant Data

Kevitsa process water showed a strong seasonal variation characterized by increased conductivity and concentration of dissolved species in winter. This characteristic is related to the locking of the clean water in the ice cap, covering the tailings pond and, consequently, the concentration of the contaminants in the water phase. The melting of snow then causes a sharp decrease in conductivity and dissolved species concentration around March–April [21]. As the concentration of all elements and compounds were increasing in winter-time due to the ice cap, the comparison with summer-time values was deemed more suitable.

The difference between the final water from the dissolution with DW at 20 °C (DW20_8) and the average value observed on-site during summer 2018 for chloride, potassium, magnesium, sodium, and total sulfur was −12%, −1.9%, 1.5%, −13%, and 7.6% (Table 3). For these elements, the plant value was reached during the dissolution loops. However, the concentrations of calcium and sulfate in the DW20_8 water were much lower (−65.6% and −38.5%, respectively) than the value observed on-site. Nevertheless, the historical operating condition data received from the mine site indicated a long period when the plant was operated with an overdose of lime to depress pentlandite in the copper circuit. This was likely the reason for the higher concentration of calcium in the process water than in the laboratory dissolution tests. Besides that, a preliminary study on the same ore has shown that the addition of lime affected the formation of sulfate. This observation was in agreement with the literature [4], where it is stated that there should be a correlation between sulfate and calcium concentration when examining the process water of Zinkgruvan concentrator. Additionally, an internal survey of the Kevitsa plant water circuit also showed that the mine pit contributed a great import of sulfate and metals, most probably due to the bacterial activities, which were not simulated by the dissolution loop.

Table 3. Comparison of composition between the final water from the dissolution with DW at 20 °C (DW20_8) and the average value recorded on-site. The difference is shown in percentage.

Variable	SPC	Cl ⁻	SO ₄ ²⁻	K ⁺	Ca ²⁺	Mg ²⁺	Na ⁺	TotS	Si	Fe	Ni	Cu	Co	P
Unity	μS/cm	mg/L	mg/L	mg/L	mg/L	mg/L	mg/L	mg/L	mg/L	μg/L	μg/L	μg/L	μg/L	μg/L
DW20_8	2118	390	420	52	81	67	180	260	5	50	21	2	0.2	7
Plant	2650	440	620	53	160	66	205	241	9	700	10	3	2	140
Diff. (%)	−22	−12	0.38	−2	−66	2	−13	8	−58	−173	71	−39	−170	−182

Table 3 shows that the concentrations of iron and cobalt were much higher in the process water than in the final dissolution water. Again, this could be explained by an extra import of metals into the process water from the pit water. According to the plant water circuit, in summer-time, the pit water was mixed into the process water. Due to the problem of acid mine drainage, the pH of the pit water stream was low and contained high concentrations of metals. The higher amount of phosphorus in the plant water is originated from the decomposition of a P-containing collector, Aerophine, used as the collector in the copper flotation circuit.

The historical data analysis also showed a tendency of leveling for most of the major elements. The trend was similar to the one observed in the dissolution loops (Figure 6).

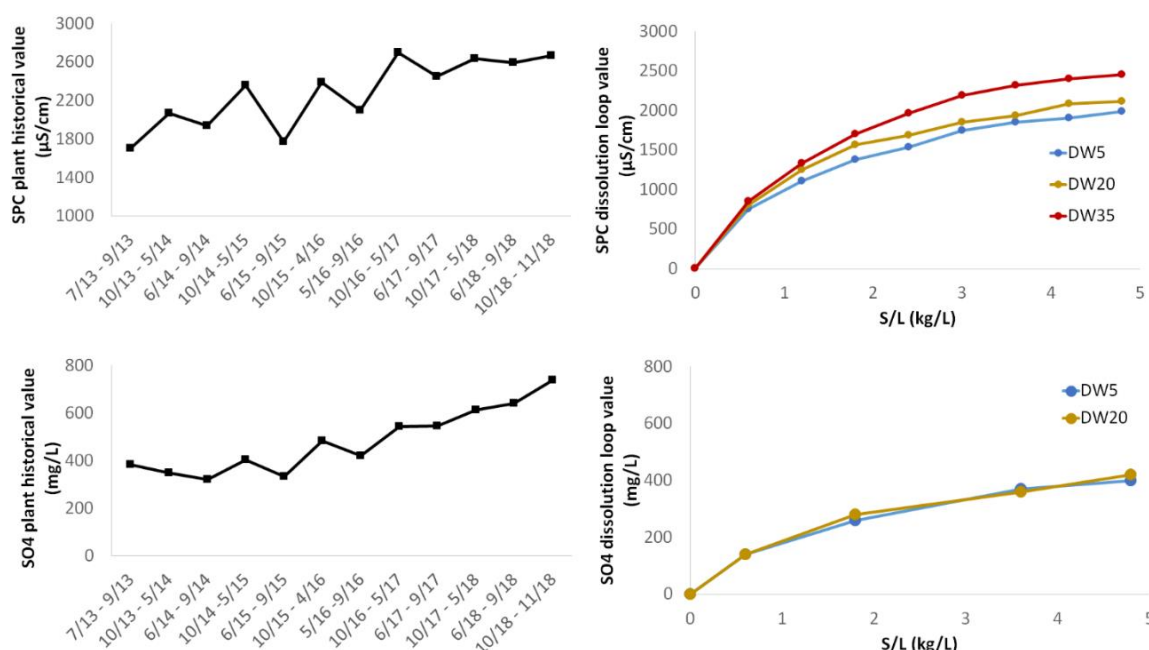

Figure 6. Process water SPC as a function of operational time at Kevitsa mine (left) and the change in SPC in the recycled water as a function of the S/L ratio (right).

The SPC of the process water increased from around 1500 $\mu\text{S}/\text{cm}$ to 2500 $\mu\text{S}/\text{cm}$ from 2013 to 2017 and currently stabilized around 2500 $\mu\text{S}/\text{cm}$ over the last two years. The same tendency has been observed in all major elements, except for sulfate.

Since summer 2017, the cyclic behavior of sulfate concentration in the process water was not observed anymore, and the level of sulfate kept increasing steadily. Similar behavior was observed in metals concentrations, such as iron and nickel. It could be explained by the fact that in the last two years, the temperature during summer in northern Finland was particularly high. High temperatures favor bacteria and oxidation activities on the ore. Therefore, the amounts of sulfate and metals released into the process water have increased dramatically.

4. Application of the Dissolution Test for Predicting the Impact of Recycling Water on the Flotation Performance

This section aims to demonstrate a potential application of the dissolution loop for predicting the impact of recycling water on the flotation performance. The study consisted of using the dissolution loop to create the “potential future process water” referred to in the following text as dissolution loop water (DLW). Then, the flotation tests were carried with both starting water (SW) and DLW. To validate the methodology, the flotation of the actual process water (PW) of the plant was carried out and compared with the results of the flotation with DLW.

Flotation tests were conducted according to the Boliden Kevitsa laboratory standard selective rougher flotation flow sheet and reagents dosage. The detailed flotation test conditions are given in Table 4. According to the flowsheet, the sequential selective rougher flotation was conducted for both copper minerals (chalcopyrite and cubanite) and nickel mineral (pentlandite). Both rougher copper and nickel flotation was performed at two stages. The same reagents were used in the laboratory as were used in the concentrator plant. Aeroprime (3418 A) was used as the collector in rougher copper flotation. Sodium Isopropyl Xanthate (SIPX) was used as the collector in the nickel rougher flotation stage. Carboxymethylcellulose (CMC) was used to depress the gangue minerals, and Nasfroth was used as frother throughout the circuit. An Outotec-GTK laboratory flotation machine was used for the flotation tests. The machine worked with automated scrapers, and the scraping frequency was adjustable. The first concentrates (i.e., Cu_C1 and Ni_C1) and second concentrates (i.e., Cu_C2 and Ni_C2) were recovered with a scraping frequency of one every 5 s and 15 s, respectively. The froth

used as frother throughout the circuit. An Outotec-GTK laboratory flotation machine was used for the flotation tests. The machine worked with automated scrapers, and the scraping frequency was adjustable. The first concentrates (i.e., Cu_C1 and Ni_C1) and second concentrates (i.e., Cu_C2 and Ni_C2) were recovered with a scraping frequency of one every 5 s and 15 s, respectively. The froth depth was kept constant at 2 cm during copper flotation and 1 cm during nickel flotation by the addition of the water of interest. The flotation test products, concentrates, and tailings were dried and weighted on-site and sent to the analytical lab.

Table 4. Flotation procedure.

Stage	Time (min)		pH	pH Modifier	CMC	Aerophine	Nasf. 240	SIPX	Product Name
	Cond.	Flot.							
Conditioning	2	3	10.5	Lime	35	5	30		
	0.5								
Cu flotation	3	5	10.5	Lime					Cu_C1
		5							
Cu flotation	2	5	9.5	H ₂ SO ₄					Cu_C2
	2	2							
Conditioning	2	0.5			15		15	75	
	0.5								
Ni flotation		7.5							Ni_C1
		7.5							

Cond.: Conditioning; Flot.: Flotation; CMC: Carboxymethylcellulose; Nasf. 240: Nafion 240; SIPX: Sodium Isopropyl Xanthate.

The recovery-grade results for the Cu and Ni flotation circuit performed with starting water (SW), dissolution loop water (DLW), and process water (PW) are shown in Figure 7. All the tests were performed in duplicate to investigate the reproducibility of the approach. The process water was freshly collected from the feeding point to the flotation tank on the morning of the day when the test was performed. The maximum aging time between the last test and the collection time was 90 min. Since the waiting time was short, it was reasonable to assume that the PW composition was constant during the tests.

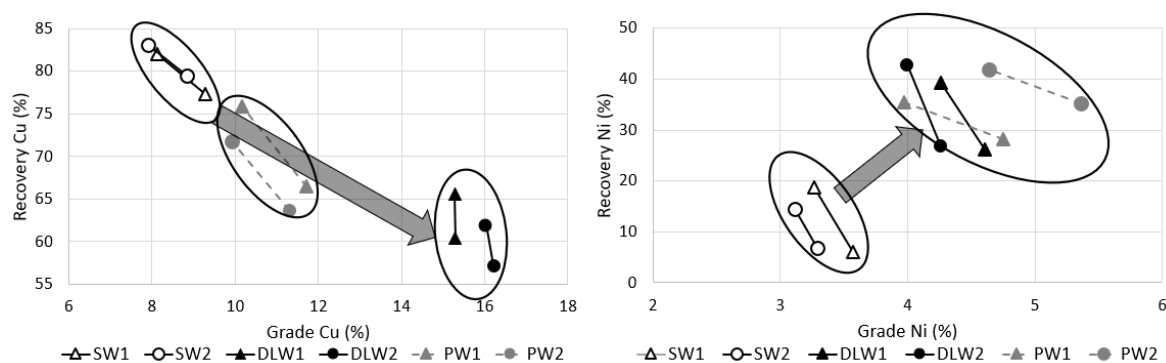

Figure 7. Recovery-grade curves for the Cu and Ni flotation performed with starting water (SW); dissolution loop water (DLW), and process water (PW).

The grade-recovery curve for the Cu flotation indicated that the flotation with process water decreased the recovery of Cu but increased the grade. The drop in the recovery could be up to 12%, while the grade increased by almost 3%. The flotation with the DLW indicated the same trend, while the grade increased by almost 3%. The flotation with the DLW indicated the same trend. The flotation with the DLW predicted a similar drop, around 15%. However, the increase in grade was higher than the reality, around 8% instead of 3%. Nevertheless, the tendency was similar.

In terms of Ni flotation, the flotation with DLW and PW gave similar results. The grade and recovery of Ni increased significantly compared to the flotation with starting water. The grade increased by around 1.5%, and the recovery increased by almost 20%. The *p*-values obtained from ANOVA single factor analysis provided more than 99% confidence in rejecting the null hypothesis and accepting that the DLW and PW have different effects than RW (Supplementary Table S6). These results supported two important findings:

In terms of Ni flotation, the flotation with DLW and PW gave similar results. The grade and recovery of Ni increased significantly compared to the flotation with starting water. The grade increased by around 1.5%, and the recovery increased by almost 20%. The *p*-values obtained from ANOVA single factor analysis provided more than 99% confidence in rejecting the null hypothesis and accepting that the DLW and PW have different effects than RW (Supplementary Table S6). These results supported two important findings:

1. The potential effect of recycling water can be predicted by the flotation with the water from the dissolution loop. Even though this approach could not predict the exact effect, it can point out the main tendency.
2. The flotation with fresh water and recycled water (or process water) gave different results. This indicates that if the plant is planned to have a recirculation circuit, the metallurgical testing to design the plant should not be done with freshwater or any local tap water but dissolution loop water. Otherwise, the results can lead to an inappropriate design.

5. Importance, Applicability, Limits, and Uncertainty of the Dissolution Test Protocol

As mentioned in the introduction, this section is dedicated to discussing the hypothesis used to set up this study. Through that, the objective was to highlight the importance and the impact of the obtained results as well as its limits and uncertainty

The first assumption is that using synthetic water recipes is not suitable to study the impact of recycling water on the ore flotability since the recycled water observed in a processing plant is highly dynamic. Literature indicates that most researchers choose to use synthetic water to study the effect of water quality of the flotation performance [28,36–38]. The convenience of using synthetic water is undeniable as it provides a flexible condition and allows to investigate the effect of specific conditions. However, the disadvantages exist: the synthetic water matrix is mostly stable, oversimplified, and the ore might never get into contact with such a water matrix in the true plant. The complexity, dynamicity, and instability of mining process waters have been highlighted by many researchers [2,9,27,34,39,40]. Since process water quality is affected by many parameters, such as the dissolution of soluble mineral phases present in the ore (soluble salt), surface oxidation, followed by dissolution during grinding and flotation, water blending strategy, quality of water streams, operating conditions, and ore variations, the variation of water quality could range from very fast to very slow [9]. Additionally, not all variables have the same frequency of variation. Some operating condition-related parameters, such as pH, ORP, turbidity, residue reagents-related elements, can vary daily or even hourly when other parameters could have a longer frequency of variation [21]. This type of dynamicity could not be reproduced just by using synthetic plant water. Additionally, in the case of recycling water, the water matrix could be extremely complicated with the presence of not only salts that accumulated due to the ore oxidation and dissolution but also suspended solids, bacteria, residues of reagents, residues of explosives, and different organic compounds. On top of that, the complexity of the matrix is aggravated by the instability of the process water. Both organic and inorganic compounds can react with each other and/or degrade in the water. For example, some reduced compounds can oxidize into some higher degree of oxidation compounds in the presence of oxygen. A very common example seen in the literature is the formation of thiosalts when processing sulfide ores [27,34,40,41]. Thiosalts, which are also known as polythionates, are sulfur oxyion compounds, and the general structure is $S_nO_m^{2-}$ [34]. Among them, researchers mostly focus on thiosulfate, tetrathionate, and trithionate [27,34,40,42]. Only thiosulfate and tetrathionate are found in the market, and trithionate could be synthesized with 96–100% purity [40]. The synthetic procedure requires some quite strong chemical background [43] and laboratory facilities. The oxidation of thiosalts can kinetically produce diverse products, but thermodynamically, the final product is sulfate [34,40]. Additionally, it is difficult to know the exact composition of the process water since there are limited analytical methods available to analyze the detailed speciation of the S compounds in the water. Most of the time, the analysis procedure focuses on thiosulfate, but thiosulfate is usually not the major thiosalt present in process water [39]. Since the analysis procedure has a

large degree of uncertainty, and not all $S_nO_m^{2-}$ species are commercially available, it is reasonable to conclude that it is impossible to reproduce the composition of such process waters in the laboratory. Therefore, using solely synthetic water to investigate the effect of recycled water on the flotation performance of a true plant is not pertinent. Hence, there is the importance of producing a laboratory water matrix that is comparable to the process water.

The second assumption is that the prediction of the water quality variation could be possible if the pathway of the ore in the plant is simulated. The easiest way to mimic it is by using the laboratory flotation procedure used by the same plant. Actually, literature provides many tests for the dissolution of the ore. They are built mostly for leaching and predicting the quality of mining wastewaters [22,44–46]. The disadvantage of those methods is that the ore is not placed in similar plant-like conditions. Since, in theory, the processing plant is scaled-up based on the tests obtained by the same laboratory testing procedure, laboratory flotation procedure offers the closest condition to the plant. However, the limitation of the dissolution loop set-up could be seen from the discrepancies between the prediction and the true plant water matrix that are shown in Section 3. The differences originate from the fact that the dissolution loop is still a simplified process compared to the complex interactions between ore, water, and operating conditions that can affect the quality of process water in the true plant. The discrepancies are caused by events that the dissolution loop does not simulate, such as ore variation, water blending, seasonal variations, residual reagents, and bacterial activities. In the future, this basic protocol can be further extended by the deliberate inclusion of the above parameters.

Assuming that the water quality could be predicted, its effect on the flotation on plant performance could also be predicted with some degree of uncertainty. Generally, typical plant design and optimization are based on several metallurgical batch flotation and pilot-scale tests using fresh tap water in the location where the testing is done. Important factors for the flotation, such as the quality of the recycled water, temperature variation, are generally not taken into consideration [7]. Therefore, as a consequence, there is a gap of validation between plant design and laboratory testing and plant performance. More importantly, the fact that these factors are not taken into consideration in the plant design phase and process selection could lead to severe financial risks because of changing process water quality, leading to declining plant performance or unexpected plant maintenance needs (e.g., due to scaling/gypsum formation).

The results of the flotation test show that indeed the effect of recycled water on the plant flotation performance could be predicted. However, one should keep in mind that testing results from one mine site are not sufficient to generalize the observation worldwide. Since no similar studies have been reported in the literature, the results could not be analyzed in the light of previous studies. Therefore, the presented protocol needs to be treated as a framework for further tests with ores from other mines to validate the dissolution protocol and its applicability for different ore types.

Besides the potential capacity of predicting the effect of recycling water on the ore flotability, the dissolution loop could also help to predict the potential effect of water variation on plant maintenance. That is particularly important for the plants that process sulfide ores and use lime as a pH modifier. The oxidation of sulfide results in sulfate as the final product. With the addition of calcium hydroxide, gypsum can precipitate when the solubility of calcium sulfate is reached. Since gypsum can block the pipes and pumps, costly maintenances are often needed. Therefore, knowing the potentially harmful components that might affect the plant maintenance would allow the process engineers to include, e.g., appropriate water treatment facilities already in the design phase.

It must be emphasized that this work focused on predicting the effect of recycling on water quality variation. However, many other applications of the dissolution loop could be considered. In this paper, we showed a potential application in predicting the effect of recycled water on ore flotability. Moreover, the dissolution water could also be used as a baseline for studying the effect of some specific compounds on the flotation performance. This would be a new and more realistic approach than using synthetic water recipes that are created based on some average value of another plant that

processes a similar type of ore or a recipe that simply multiplies all elements by a certain ratio [36,38]. The dissolution loop, therefore, could complement the traditional pure synthetic water approach. The dissolution loop creates baseline water that possesses the important characteristic of the process water, such as mine specific, unstable, dynamic, complex, and the effect of some specific compounds can be detected by spiking the baseline water with the compounds that are likely to accumulate in the recycled water during the processing of the ores.

6. Conclusions

The dissolution loop's laboratory protocol described in this paper is an important tool that allows the prediction of the water quality variation over time due to the dissolution of the ore when the plant is operated in closed water circulation. It defines the main direction into which the water matrix will evolve. The results showed that the final water composition came close to the in-situ plant water quality in terms of major elements and some of the minor elements in the studied system. Additionally, good reproducibility in terms of dissolution results was observed. Therefore, it could be used as a tool to complement the traditional processing plant design and water treatment facility selection and dimensioning.

The findings of this study also suggested that synthetic water recipes that multiply all elements by a certain ratio are not appropriate to study the effect of water on the flotation performance in reality. This is a direct consequence of the fact that the rate of accumulation is different for different elements and varies as a function of temperature, as shown in this study. In reality, the dissolution rate also varies as a function of other parameters, such as ore type, degree of oxidation of the ore, the quality of the recycled and make-up water, etc.

Several possibilities of application of the dissolution test to study the potential effect of the water quality on the ore flotability has been discussed. In this study, we demonstrated that the dissolution loop could be used to predict the effect of recycling water on flotation performance. Even though the exact variation in grade and recovery cannot be forecasted, the direction of the changes caused by the water quality can be predicted.

Since this is the first study that attempts to predict the water matrix variation due to the recycling of water, to generalize the results, more validation tests are needed. However, one must keep in mind that the dissolution from the ore during grinding and floatation is not the only factor that influences the process water matrix in a true plant. Indeed, the major discrepancies in terms of calcium, sulfate, and metals observed in this study were partly due to the fact that the dissolution test did not simulate other parameters that could affect the process water quality on-site, such as ore variability, tailing ponds, make-up water quality, water blending strategy, operating conditions, and bacterial activities. All those parameters are not yet taken into consideration in the dissolution loop in this basic protocol. In the future, this basic protocol can be further extended by the deliberate inclusion of the above parameters.

Supplementary Materials: The following are available online at <http://www.mdpi.com/2075-163X/10/8/653/s1>, Figure S1: Particle size distribution of the sample after grinding, Table S1: Mineralogy composition of the ore used for the study (Pn: Penlandite, Ccp: Chalcopyrite, Cub: Cubanite, Po: Pyrrhotite, Py: Pyrite, Hbl: Hornblende, Di: Diopside), Table S2: Chemical composition of the ore. Cu and Ni were analysed in term of sulphide form (S) and total from all form (T), Table S3: Composition of the RW, Table S4: Analysis methods, Limit of Detection (L.D.) and margin of error provided by the contracted laboratories for water analysis, Table S5: The t-test results for comparing means of the pH measured in dissolution loop water (DLW) and the pH observed in the process water (PW), Table S6: ANOVA analysis for Cu recovery, Cu grade, Ni Recovery and Ni Grade results from the flotation test with DLW, SW, and PW.

Author Contributions: Conceptualization, T.M.K.L.; methodology, T.M.K.L.; formal analysis, T.M.K.L.; investigation, T.M.K.L.; writing—original draft preparation, T.M.K.L.; writing—review and editing, N.S.; visualization, T.M.K.L.; supervision, N.S., O.D.; project administration, N.S.; funding acquisition, N.S., O.D. All authors have read and agreed to the published version of the manuscript.

Funding: This research received funding from the European Union H2020 program under grant agreement no 730480, ITERAMS project.

Acknowledgments: The authors would like to acknowledge Boliden Kevitsa Mine for their support, Ertuna Cakir and Mathew Dzingai for their help in the experimental work, and Ngoni Mhonde for advice during the writing.

Conflicts of Interest: The authors declare no conflict of interest.

References

1. Johnson, N. Issues in maximisation of recycling of water in a mineral processing plant. In Proceedings of the Water in Mining Conference, Brisbane, Australia, 13–15 October 2003; pp. 239–246.
2. Schumann, R.; Levay, G.; Ametov, I. Impact of recycling on process water quality in mineral processing. In Proceedings of the Water in Mining Conference Proceedings 2009, Perth, Australia, 15–17 September 2009; pp. 79–86.
3. Ikumapayi, F.; Johansson, B.; Rao, K.H. Recycling of process water in sulfides processing and flotation selectivity. In Proceedings of the XXV International Mineral Processing Congress (IMPC 2010), Brisbane, Australia, 6–10 September 2010; pp. 4079–4088.
4. Forssberg, K.S.E.; Hallin, M.I. Process water recirculation in a lead-zinc plant and other sulphide flotation plants. *Chall. Miner. Process.* **1989**, *452–466*. [[CrossRef](#)]
5. Ikumapayi, F.K.; Makitalo, M.; Johansson, B.; Hanumantha Rao, K. Recycling process water in complex sulphide ore flotation: Effect of calcium and sulphate on sulfide minerals recovery. In Proceedings of the 26th XXV International Mineral Processing Congress, New Delhi, India, 23–28 September 2012; pp. 4411–4425.
6. Rao, S.R.; Finch, J.A. A review of water re-use in flotation. *Miner. Eng.* **1989**, *2*, 65–85. [[CrossRef](#)]
7. Pietrobon, M.C.; Grano, S.R.; Greet, C. Matching laboratory and plant performance—A case study of the elura lead circuit, pasminco australia limited. *Miner. Eng.* **2004**, *17*, 811–824. [[CrossRef](#)]
8. Liu, L.; Rao, S.R.; Finch, J.A. Technical note laboratory study of effect of recycle water on flotation of a cu/znc sulphide ore. *Miner. Eng.* **1993**, *6*, 1183–1190. [[CrossRef](#)]
9. Levay, G.; Schumann, R. A systematic approach to water quality management in the minerals processing industry. In Proceedings of the Water in Mining Conference, Brisbane, Australia, 14–16 November 2006; pp. 277–287.
10. Levay, G.; Dunne, R.; Hart, S. Managing process water quality in base metal sulfide flotation. In Proceedings of the Water in Mining; the Role of Water in a Sustainable Minerals Industry, Brisbane, Australia, 13–15 October 2003; pp. 251–260.
11. Slatter, K.A.; Plint, N.D.; Cole, M.; Dilsook, V.; De Vaux, D.; Palm, N.; Oostendorp, B. Water management in anglo platinum process operations: Effects of water quality on process operations. In Proceedings of the International Mine Water Conference, Pretoria, South Africa, 19–23 October 2009; pp. 46–55.
12. Liu, W.; Moran, C.J.; Vink, S. A review of the effect of water quality on flotation. *Miner. Eng.* **2013**, *53*, 91–100. [[CrossRef](#)]
13. Farrokhpay, S.; Zanin, M. Effect of water quality on froth stability in flotation. In Proceedings of the Australasian Conference on Chemical Engineering, Sydney, Australia, 18–21 September 2011.
14. Wellham, E.J.; Elber, L.; Yan, D.S. The role of carboxy methyl cellulose in the flotation of a nickel sulphide transition ore. *Miner. Eng.* **1992**, *5*, 381–395. [[CrossRef](#)]
15. Kurniawan, A.U.; Ozdemir, O.; Nguyen, A.V.; Ofori, P.; Firth, B. Flotation of coal particles in mgcl₂, nacl, and nacl₃ solutions in the absence and presence of dowfroth 250. *Int. J. Miner. Process.* **2011**, *98*, 137–144. [[CrossRef](#)]
16. Levay, G.; Smart, R.; Skinner, W. The impact of water quality on flotation performance. *SAIMM J.* **2001**, *101*, 69–75.
17. Fornasiero, D.; Ralston, J. Effect of surface oxide/hydroxide products on the collectorless flotation of copper-activated sphalerite. *Int. J. Miner. Process.* **2006**, *78*, 231–237. [[CrossRef](#)]
18. Senior, G.D.; Trahar, W.J. The influence of metal hydroxides and collector on the flotation of chalcopyrite. *Int. J. Miner. Process.* **1991**, *33*, 321–341. [[CrossRef](#)]
19. Edwards, C.R.; Kipkie, W.B.; Agar, G.E. The effect of slime coatings of the serpentine minerals, chrysotile and lizardite, on pentlandite flotation. *Int. J. Miner. Process.* **1980**, *7*, 33–42. [[CrossRef](#)]
20. Pickett, D.E.; Joe, E.G. Water Recycling Experience in Canadian Mills. *SME Trans. AIME* **1974**, *256*, 230–235.
21. Muzinda, I.; Schreithofer, N. Water Quality Effects on Flotation: Impacts and Control of Residual Xanthates. *Miner. Eng.* **2018**, *125*, 34–41. [[CrossRef](#)]

22. Muniruzzaman, M.; Kauppila, P.M.; Karlsson, T. Water quality prediction of mining waste facilities based on predictive models. Available online: http://tupa.gtk.fi/raportti/arkisto/16_2018.pdf (accessed on 20 July 2020).
23. Abbassi, R.; Khan, F.; Hawboldt, K. prediction of minerals producing acid mine drainage using a computer-assisted thermodynamic chemical equilibrium model. *Mine Water Environ.* **2009**, *28*, 74–78. [[CrossRef](#)]
24. Declercq, J.; Charles, J.; Bowell, R.; Warrender, R.; Barnes, A. comparison of thermodynamic equilibrium and kinetic approach in the predictive evaluation of waste rock seepage quality in northern finland. In Proceedings of the IMWA Congress, Lappeenranta, Finland, 25–30 June 2017; pp. 664–671.
25. Musuku, B.; Muzinda, I.; Lumsden, B. Cu–Ni processing improvements at first quantum’s kevitsa mine. *Miner. Eng.* **2016**, *88*, 9–17. [[CrossRef](#)]
26. Santaguida, F.; Luolavirta, K.; Lappalainen, M.; Ylinen, J.; Voipio, T.; Jones, S. The Kevitsa Ni-Cu-PGE deposit in the Central Lapland greenstone belt in Finland. In *Mineral deposits of Finland*; Maier, W.D., Lahtinen, R., O’Brien, H.B.T.-M., Eds.; Elsevier: Amsterdam, The Netherlands, 2015; pp. 195–210. [[CrossRef](#)]
27. Wasserlauf, M.; Dutrizac, J.E. Canmet’s project on the chemistry, generation and treatment of thiosalts in milling effluents. *Can. Metall. Q.* **1984**, *23*, 259–269. [[CrossRef](#)]
28. Ikumapayi, F.; Rao, K.H. Recycling process water in complex sulfide ore flotation: Effect of calcium and sulfate on sulfide minerals recovery. *Miner. Process. Extr. Metall. Rev.* **2015**, *36*, 45–64. [[CrossRef](#)]
29. Dávila-Pulido, G.I.; Uribe-Salas, A.; Álvarez-Silva, M.; López-Saucedo, F. The role of calcium in xanthate adsorption onto sphalerite. *Miner. Eng.* **2015**, *71*, 113–119. [[CrossRef](#)]
30. Tabelin, C.B.; Igarashi, T.; Takahashi, R. Mobilization and speciation of arsenic from hydrothermally altered rock in laboratory column experiments under ambient conditions. *Appl. Geochem.* **2012**, *27*, 326–342. [[CrossRef](#)]
31. Tabelin, C.B.; Sasaki, R.; Igarashi, T.; Park, I.; Tamoto, S.; Arima, T.; Ito, M.; Hiroyoshi, N. Simultaneous leaching of arsenite, arsenate, selenite and selenate, and their migration in tunnel-excavated sedimentary rocks: II. kinetic and reactive transport modeling. *Chemosphere* **2017**, *188*, 444–454. [[CrossRef](#)]
32. Tabelin, C.B.; Sasaki, R.; Igarashi, T.; Park, I.; Tamoto, S.; Arima, T.; Ito, M.; Hiroyoshi, N. Simultaneous leaching of arsenite, arsenate, selenite and selenate, and their migration in tunnel-excavated sedimentary rocks: I. column experiments under intermittent and unsaturated flow. *Chemosphere* **2017**, *186*, 558–569. [[CrossRef](#)] [[PubMed](#)]
33. Peng, X.Y.; Wang, Y.Y.; Chai, L.Y.; Shu, Y.D. Thermodynamic equilibrium of CaSO₄-Ca(OH)₂-H₂O system. *Trans. Nonferr. Met. Soc. China* **2009**, *19*, 249–252. [[CrossRef](#)]
34. Miranda-Trevino, J.C.; Pappoe, M.; Hawboldt, K.; Bottaro, C. The importance of thiosalts speciation: Review of analytical methods, kinetics, and treatment. *Crit. Rev. Environ. Sci. Technol.* **2013**, *43*, 2013–2070. [[CrossRef](#)]
35. Boardman, D.I.; Glendinning, S.; Rogers, C.D.F. The influences of Iron (III) and Lead (II) contaminants on lime-stabilised clay. *Géotechnique* **2004**, *54*, 467–486. [[CrossRef](#)]
36. Manono, M.S.; Corin, K.C.; Wiese, J.G. An investigation into the effect of various ions and their ionic strength on the flotation performance of a platinum bearing ore from the merensky reef. *Miner. Eng.* **2012**, *36*, 231–236. [[CrossRef](#)]
37. Manono, M.S.; Corin, K.C.; Wiese, J.G. the effect of ionic strength of plant water on foam stability: A 2-phase flotation study. *Miner. Eng.* **2013**, *40*, 42–47. [[CrossRef](#)]
38. Bıçak, Ö.; Ekmekçi, Z.; Can, M.; Öztürk, Y. The effect of water chemistry on froth stability and surface chemistry of the flotation of a Cu–Zn sulfide ore. *Int. J. Miner. Process.* **2012**, *102*, 32–37. [[CrossRef](#)]
39. Whaley-Martin, K.; Marshall, S.; Nelson, T.E.C.; Twible, L.; Jarolimek, C.V.; King, J.J.; Apte, S.C.; Warren, L.A. A mass-balance tool for monitoring potential dissolved sulfur oxidation risks in mining impacted waters. *Mine Water Environ.* **2020**, 1–17. [[CrossRef](#)]
40. Vongporm, Y. Thiosalt behaviour in aqueous media. *Meml. Univ. Newfoundl.* **2008**, *1*, 26–36. [[CrossRef](#)]
41. Kuyucak, N. Management of thiosalts in mill effluents by chemical oxidation or buffering in the lime neutralization process. *Miner. Eng.* **2014**, *60*, 41–50. [[CrossRef](#)]
42. Öztürk, Y.; Bıçak, Ö.; Özdemir, E.; Ekmekçi, Z. Mitigation negative effects of thiosulfate on flotation performance of a Cu-Pb-Zn sulfide ore. *Miner. Eng.* **2018**, *122*, 142–147. [[CrossRef](#)]
43. Kelly, D.P.; Wood, A.P. Synthesis and determination of thiosulfate and polythionates. In *Inorganic Microbial Sulfur Metabolism*; Elsevier: Amsterdam, The Netherlands, 1994; Volume 243, pp. 475–501. [[CrossRef](#)]

44. Maest, A.; Kuipers, J.R.; Travers, C.L.; Atkins, D.A. *Predicting Water Quality at Hardrock Mines: Methods and Models, Uncertainties, and State-of-the-Art*; Book; Kuipers & Associates and Buka Environmental: Boulder, CO, USA, 2005.
45. Ma, D.; Duan, H.; Cai, X.; Li, Z.; Li, Q.; Zhang, Q. A global optimization-based method for the prediction of water inrush hazard from mining floor. *Water* **2018**, *10*, 1618. [[CrossRef](#)]
46. Moran, R.E. Is This number to your liking? Water quality predictions in mining impact studies. In *Prediction: Science, Decision Making and the Future of Nature*; Sarewitz, D., Pielke, R.A., Jr., Byerly, R., Jr., Eds.; Island Press: Washington, DC, USA, 2000; pp. 185–198.



© 2020 by the authors. Licensee MDPI, Basel, Switzerland. This article is an open access article distributed under the terms and conditions of the Creative Commons Attribution (CC BY) license (<http://creativecommons.org/licenses/by/4.0/>).